

710 / 710 ASME

On-Demand Water Heater

Installation Manual and Owner's Guide



ANSI Z21.10.3
and CSA 4.3



For supplying potable
hot water

ASME model ONLY

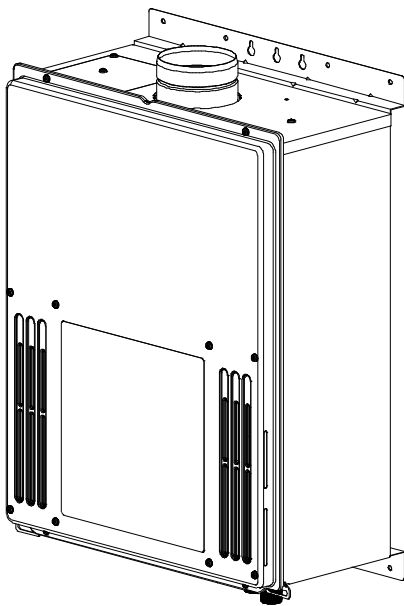

Gas Tankless Water Heater™

710 / 710 ASME Models

*Suitable for potable water heating and space-heating **

**Please refer to local codes for space-heating compliance.*

FEATURING

- ENDLESS HOT WATER
- ON-DEMAND USAGE
- COMPACT, SPACE SAVING
- ENERGY CONSERVATION
- COMPUTERIZED SAFETY
- NO PILOT LIGHT
- EASY-LINK SYSTEM

WARNING

This product must be installed and serviced by a licensed plumber, a licensed gas fitter, or a professional service technician. Improper installation and/or operation, or installation by an unqualified person, will void the warranty.

WARNING

If the information in this manual is not followed exactly, a fire or explosion may result, causing property damage, personal injury, or death.

If you have any questions, please call or write to:

500 Tennessee Waltz Parkway
Ashland City, TN 37015

Toll Free: 1-877-737-2840

CONTENTS

SPECIFICATIONS.....	2
INTRODUCTION.....	3
SAFETY GUIDELINES.....	4
INSTALLATION.....	5
General.....	6
Included Accessories.....	6
Outdoor Installation.....	7
Indoor Installation.....	9
Direct Intake Vent System.....	10
Venting Instructions.....	11
Gas Supply / Gas Pipe Sizing.....	15
Water Connections.....	17
Pressure Relief Valve.....	18
Electrical Connections.....	19
Remote Controller Connections.....	20
Pump Control Mode.....	21
Easy-Link System.....	24
Multi-Unit System.....	28
Initial Operation.....	30
NORMAL OPERATION.....	31
Normal Operation.....	31
Flow.....	33
Freeze Protection System.....	33
Temperature Settings.....	34
Maintenance and Service.....	35
GENERAL TROUBLESHOOTING.....	36
WIRING DIAGRAM.....	39
OPERATING SAFETY.....	40
APPLICATIONS.....	42
Re-Circulation.....	42
Dual-Purpose Heating.....	43
ADDITIONAL CLEARNCES.....	44
OPTIONAL ITEMS.....	45
COMPONENTS DIAGRAM.....	46
PARTS LIST.....	49
OUTPUT TEMPERATURE CHART.....	51
LIMITED WARRANTY.....	51

SPECIFICATIONS

Natural Gas Input (Operating Range)		Min: 24,000 Btu/h Max: 240,000 Btu/h	
Propane Input (Operating Range)		Min: 24,000 Btu/h Max: 240,000 Btu/h	
Gas Connection		3/4" NPT	
Water Connections		3/4" NPT	
Water Pressure		15 - 150 psi *	
Natural Gas Inlet Pressure		Min. 5.0" WC Max. 10.5" WC	
Propane Inlet Pressure		Min. 8.0" WC Max. 14.0" WC	
Manifold Pressure		Natural: 2.35" WC Propane: 3.55" WC	
Weight		56 lbs.	
Dimensions		H23.6"×W18.5"×D8.9"	
Ignition		Electric Ignition	
Electric	Supply	120 VAC / 60 Hz	
	Consumption	Operation	112 W (0.93 A)
		Standby	8.9 W (0.07 A)
		Freeze- Protection	187 W (1.56 A)

*40 psi or above is recommended for maximum flow

NOTE

*All references to the 710 also refer to the 710 ASME model.

*Check the rating plate to ensure this product matches your specifications.

*In accordance with ANSI Z21.10.3, CO emission does not exceed 400 PPM for normal input.

The manufacturer reserves the right to discontinue, or change at any time, specifications or designs without notice and without incurring obligations.

INTRODUCTION

- This manual provides information necessary for the installation, operation, and maintenance of the water heater.
- The model description is listed on the rating plate which is attached to the front cover of the water heater.
- Please read all installation instructions completely before installing this product.
- If you have any problems or questions regarding this equipment, consult with the manufacturer or its local representative.
- The 710 is an on-demand, tankless water heater designed to efficiently supply endless hot water for your needs.
- The principle behind the 710 Water Heater is simple:

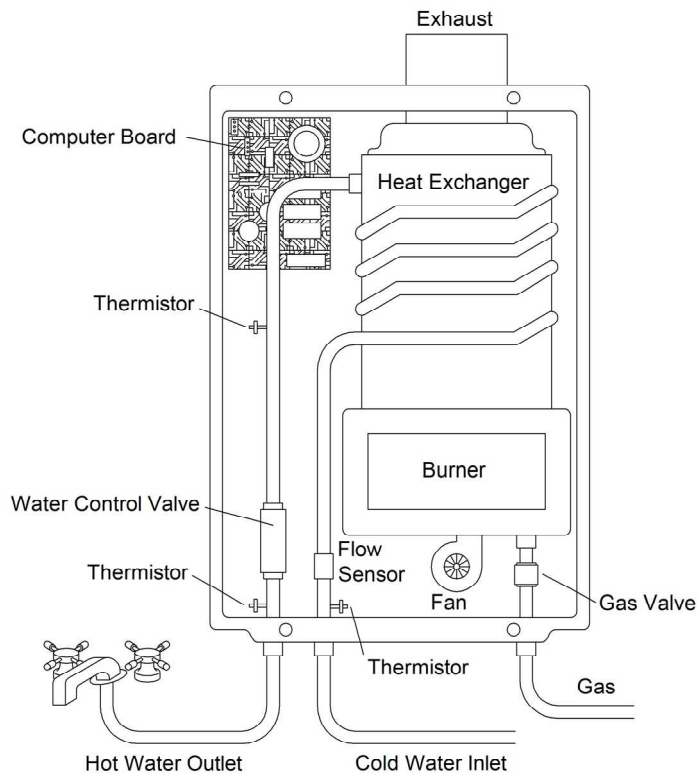

*This diagram illustrates tankless water heater design concepts only and is not accurate to the 710's physical description.

1. A hot water tap is turned on.
2. Water enters the heater.
3. The water flow sensor detects the water flow.
4. The computer automatically ignites the burner.
5. Water circulates through the heat exchanger and then gets hot.
6. The computer will modulate the gas supply valve and water flow to produce the right amount of hot water at the correct temperature.
7. When the tap is turned off, the unit shuts down.

SAFETY GUIDELINES



- Installation and service must be performed by a qualified installer (for example, a licensed plumber or gas fitter), otherwise the warranty will be void.
- The installer (licensed professional) is responsible for the correct installation of your Water Heater and for compliance with all national, state/provincial, and local codes.

PLEASE READ THIS MANUAL CAREFULLY AND FOLLOW ALL DIRECTIONS.

GENERAL

1. Follow all local codes, or in the absence of local codes, follow the most recent edition of the National Fuel Gas Code: ANSI Z223.1/NFPA 54 in the USA or CAN/CSA B149.1 Natural Gas, Propane Installation Code in Canada.
2. Properly ground the unit in accordance with all local codes or in the absence of local codes, with the National Electrical Codes: ANSI/NFPA 70 in the USA or CSA standard C22.1 Canada Electrical Code Part 1 in Canada.
3. Carefully plan where you intend to install your 710 Water Heater. Please ensure:
 - Your water heater will have enough combustible air and proper ventilation.
 - Locate your heater where water leakage will not damage surrounding areas (please refer to p. 5).
4. Check the rating plate for the correct **GAS TYPE, GAS PRESSURE, WATER PRESSURE and ELECTRIC RATING.**
*If this unit does not match your requirements, **do not install and consult with the manufacturer.**
5. If any problem should occur, turn off all hot water taps and turn off the gas. Then call a trained technician or the Gas Company or the manufacturer.

WARNING

- Water temperatures over 125°F (52°C) can cause severe burns instantly or death from scalding. The water temperature is set at 120°F (49°C) from the factory to minimize any scalding risk. Before bathing or showering always check the water temperature.



Prohibited

- Do not store or use gasoline or other flammables, vapors, or liquids in the vicinity of this appliance.
- Do not reverse the water and/or gas connections as this will damage the gas valves and can cause severe injury or death. Follow the diagram on p. 17 when installing your water heater:
- Do not use this appliance if any part has been in contact with or been immersed in water. Immediately call a licensed plumber, a licensed gas fitter, or a professional service technician to inspect and/or service the unit if necessary.
- Do not disconnect the electrical supply if the ambient temperature will drop below freezing. The Freeze Prevention System only works if the unit has electrical power. The warranty will not be covered if the heat exchanger is damaged due to freezing. Refer to the section on the Freeze Prevention System on p. 33 for more information.



INSTALLATION

All gas water heaters require careful and correct installation to ensure safe and efficient operation. This manual must be followed exactly. Read the "Safety Guidelines" section at the beginning of this manual.



CAUTION

- **The warranty will not cover damage caused by water quality.** Water hardness that leads to scale formation and/or corrosion may affect/damage the water heater. Hard water scaling and/or corrosion must be avoided or controlled by proper water treatment.
- **The manufacturer recommends using the direct-vent kit, when the water heater is installed in a beauty salon.** Some chemicals used in a beauty salon may affect the flame sensor. Water heater may not work properly.
- Although the 710 is designed to operate with minimal sound, **the manufacturer does not recommend installing the unit on a wall adjacent to a bedroom, or a room that is intended for quiet study or meditation, etc.**
- Locate your heater close to a drain where water leakage will not do damage to surrounding areas. As with any water heating appliance, the potential for leakage at some time in the life of the product does exist. The manufacturer will not be responsible for any water damage that may occur. If you install a drain pan under the unit, ensure that it will not restrict the combustion air flow.



WARNING



- **The manufacturer does not recommend installing unit in an attic due to safety issues.** If you install your 710 in an attic:
 - Make sure your unit will have enough combustion air and proper ventilation.
 - Keep the area around your water heater clean. When dust collects on the flame sensor, the water heater will shut down on errors.
 - If the above conditions cannot be met, use the direct-vent conversion kit 9007668005.
 - Locate unit for easy access for service and maintenance.
 - A drain pan is required to be installed under the water heater in case of leaks.

GENERAL

1. The manifold gas pressure is preset at the factory. It is computer controlled and should not need adjustment.
2. Maintain proper space for servicing. Install the unit so that it can be connected or removed easily. Refer to p. 7 and p. 9 for proper clearances.
3. The electrical connection requires a means of disconnection, to terminate power to the water heater for servicing and safety purposes.
4. If you will be installing the unit in a contaminated area with a high level of dust, sand, flour, aerosols or other contaminants/chemicals, they can become airborne and enter and build up within the fan and burner causing damage to the unit. In those environments (e.g. residential or commercial laundry facilities, hair salons, pet salons, chemical plants etc.), please purchase the optional direct-vent conversion kit and convert the 710 to a sealed combustion unit. Direct venting allows the 710 to draw fresh intake air from the outside. The warranty will not cover damage caused to the unit due to installation in a contaminated environment that has not been converted using the direct-vent conversion kit.
5. Particles from flour, aerosols, and other contaminants may clog the air vent or reduce the functions of the rotating fan and cause improper burning of the gas. Regularly ensure that the area around the unit is dust- or debris-free; regular maintenance is recommended for these types of environment.
6. Do not install the unit where the exhaust vent is pointing into any opening in a building or where the noise may disturb your neighbors. Make sure the vent termination meets the required distance by local code from any doorway or opening to prevent exhaust from entering a building (refer to p. 14).

INCLUDED ACCESSORIES

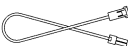
Check that the installation manual, the communication cable, and the product registration card are included with the unit.

Items	
Manual	 Qty: 1
Communication Cable	 Gray Qty: 1
Product Registration Card	 Qty: 1

OUTDOOR INSTALLATION

1. Follow all local codes, or in the absence of local codes, follow the most recent edition of the National Fuel Gas Code: ANSI Z223.1/NFPA 54 in the USA or CAN/CSA B149.1 Natural Gas, Propane Installation Code in Canada.
2. **Install outdoors only in areas with mild, temperate climates.**
3. Ensure that the unit is set for outdoor installation. Locate the left bank of dipswitches **to the bottom** of the 7-Seg. LED on the computer board. The 'OUT' dipswitch on that bank should be switched to its 'ON' (right) position (Do not adjust the right bank of dipswitches).



Make sure power to the unit is turned OFF before changing the dipswitch settings.

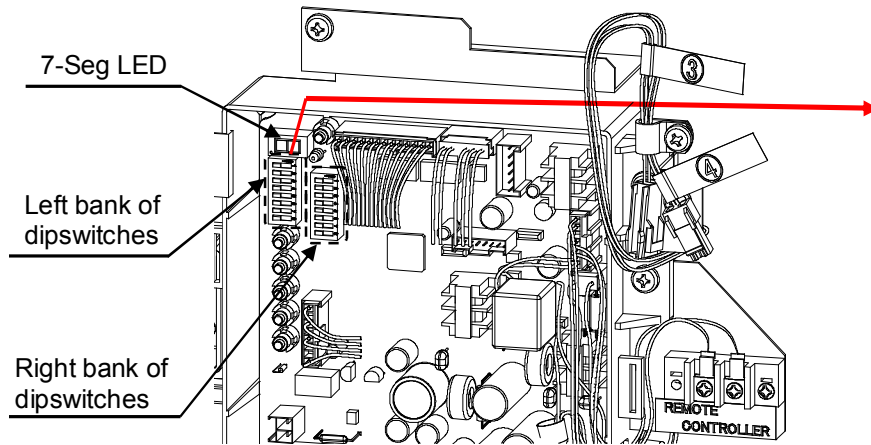

The dark square is the direction the dipswitch should be set to.

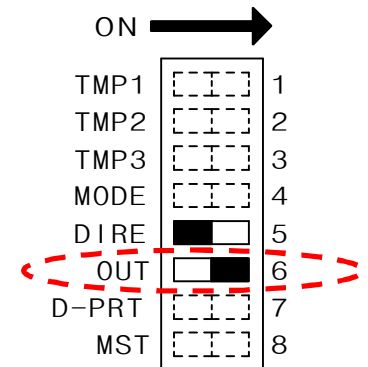

Left Bank of Dipswitches

4. The outdoor vent cap must be used when unit is installed outdoor. The manufacturer requires the use of its part No. 9007676005.
5. When installed outdoors, the 710 water heater shall be wall-mounted or mounted on a stand. Locate the water heater in an open, unroofed area and maintain the following minimum clearances:



There is a 2" clearance from the left and right sides of the unit to combustible and non-combustible surfaces. However, if any portion or area of the surface is exposed to the exhaust fumes (i.e. directly to the sides of the vent cap), that surface must be at least 24" away.

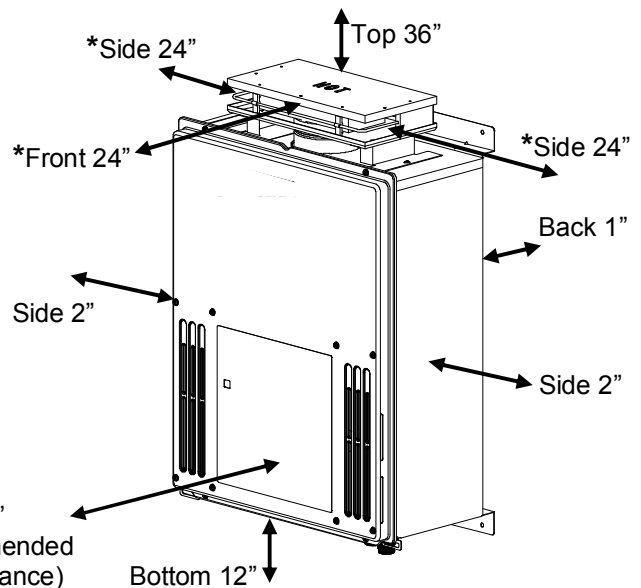

Keep the clearances.

WARNING FOR INSTALLAUON LOCATIONS

Do not install the heater where water, debris or flammable vapors may get into the flue terminal. This may cause damage to the heater and void the warranty.



Prohibited



Do not have the vent terminal pointing toward any opening into a building. Do not locate your heater in a pit or location where gas and water can accumulate.



Prohibited



Do not install this water heater under an overhang less than 3 feet from its top or eaves. The area under an overhang must be open to three sides.

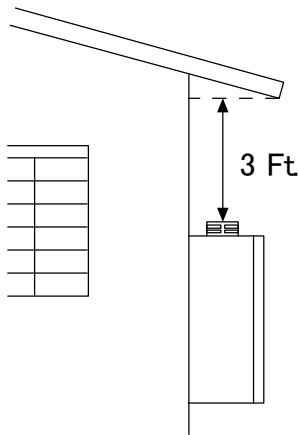

Do not install the water heater vent terminator within 1 ft. in the USA of any air intake or building opening, and within 3 ft. in Canada of any air intake or building opening. (Refer to p.14)

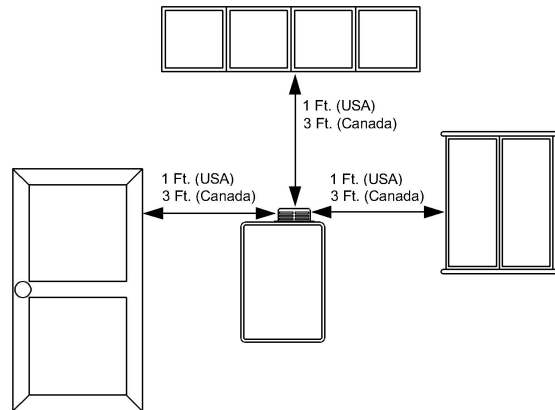

Do not install next to a dryer or any source of airborne debris that can be trapped inside the combustion chamber, unless the system is direct vented.

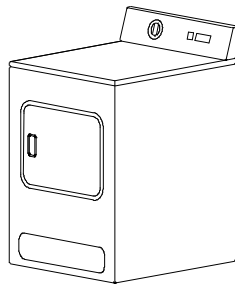

INDOOR INSTALLATION

1. Follow all local codes, or in the absence of local codes, follow the most recent edition of the National Fuel Gas Code: ANSI Z223.1/NFPA 54 in the USA or CAN/CSA B149.1 Natural Gas, Propane Installation Code in Canada.
2. When installed indoors, the 710 water heater shall be located in an area to maintain the following minimum clearances around the unit:



Keep the following clearances.

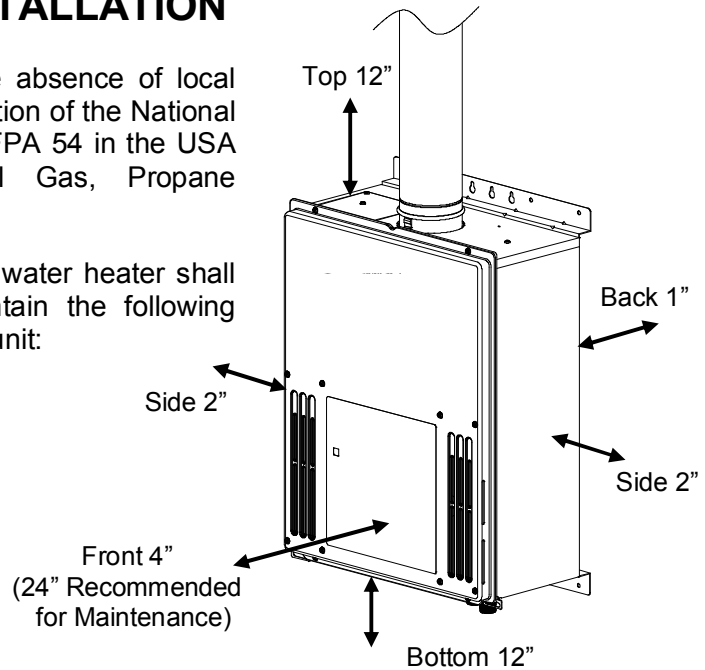

Combustion Air Supply

The water heater location must provide enough air for proper combustion and ventilation of the surrounding area. See the latest edition of ANSI Standard Z223.1 or any applicable local codes. In general, these requirements specify that if the unit is installed in a confined space, there must be a permanent air supply opening.

Minimum recommended air supply opening size for water heater:

Water heater size	When drawing make-up air from outside the building	When drawing make-up air from inside the building (from other rooms within)
MAX 240,000 BTU/h	16.0 Sq. IN	240 Sq. IN
	When combustion air is supplied from outside the building, an opening communicating directly with the outside should have a minimum free area of one square inch per 15,000 BTUH input of the total input rating of water heater in the enclosed area.	When combustion air is supplied from inside the building, an opening communicating with the rest of the dwelling should have a minimum free area of one square inch per 1,000 BTUH input of the total input rating of water heater in the enclosed area. This opening should never be less than 199 sq. in.

Combustible Air Supplied by Mechanical fan or Make up air device

The 710 water heater is equipped with a combustible air sensor that will shut off the unit when inadequate combustible air supply to unit is detected.

- If a mechanical fan or make up air device is used to supply air to the water heater or utility room, the installer should make sure it does not create drafts which could cause nuisance shutdowns.
- If a blower is necessary to provide adequate combustion air to the water heater, the blower and water heater must be set up so that the water heater cannot fire unless the blower is operating. Possible methods include the use of external flow sensors/transmitters and relays.

DIRECT INTAKE VENT SYSTEM

This 710 water heater may be converted to a direct-vent (sealed combustion) appliance by installing an adapter (Part No. 9007668005) which will bring all required combustible air from outside the building. When installing the direct-vent conversion kit, please follow all instructions included with the kit.

- The 710 must be installed in a location where the proper amount of combustible air will be available to it at all times without obstructions.
- If used as a direct-vent appliance, the 710 requires a 4" combustible air supply pipe. The intake pipe must be sealed airtight.
- Air supply pipe can be made of ABS, PVC, galvanized steel, corrugated aluminum, corrugated stainless steel or Category III stainless steel.
- Change the dipswitch settings to the direct-vent system. (See diagram below)
- Sidewall venting is recommended for the direct-vent system.
- The manufacturer recommends running the exhaust vent and the intake pipe parallel.
- **The Direct-Vent Conversion Kit has an "INLET" mark as shown below. Do not reverse the INLET and the EXHAUST connections when installing vent pipes.**



Make sure power to the unit is turned OFF before changing the dipswitch settings.

The dark square is the direction the dipswitch should be set to.

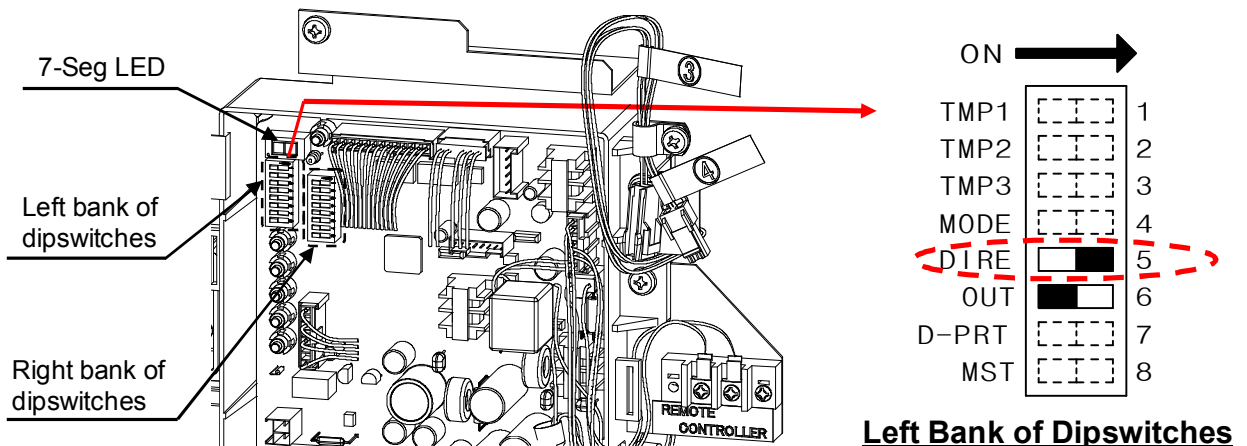

Direct-Vent Conversion Kit

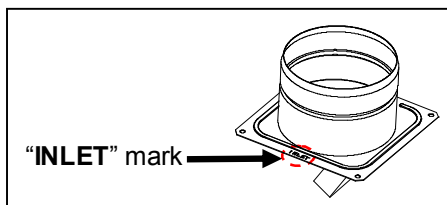

DIRECT-VENT CONVERSION KIT

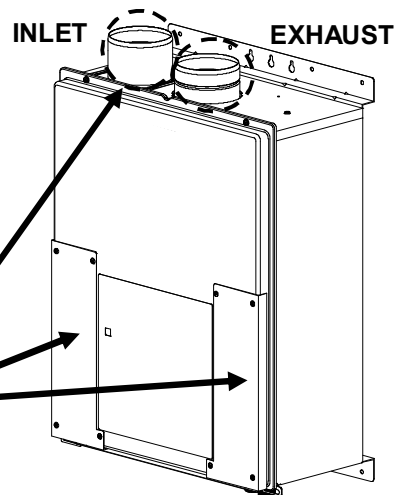

VENTING INSTRUCTIONS



WARNING: Improper venting of this appliance can result in excessive levels of carbon monoxide which can result in severe personal injury or death.

This water heater must be vented in accordance with the section "Venting of Equipment" of the latest edition of the Natural Fuel Gas Code: ANSI Z223.1, All applicable local building codes, Section 7 of CAN/CSA B149.1 Natural Gas in Canada, Propane Installation Code in Canada.

EXHAUST VENT

This is a Category III appliance and must be vented accordingly. The vent system must be sealed air tight. All seams and joints **without gaskets** must be sealed with high heat resistant silicone sealant or UL listed aluminum adhesive tape having a minimum temperature rating of 350°F. For best results, a vent system should be as short and straight as possible.

1. This water heater is a Category III appliance and must be vented accordingly with any 4" vent approved for use with Category III or Special BH type gas vent.
2. **The manufacturer recommends the "T-Vent" line manufactured by TAKAGI** (Refer to the venting brochure for details). However, the following are also UL listed manufacturers: ProTech Systems Inc. (FasNSeal), Flex-L Inc., Z-Flex Inc. (Z-Vent III), Metal-Fab Inc., and Heat-Fab Inc. (Saf-T Vent).
3. **Follow the vent pipe manufacturer's instructions when installing the vent pipe.**
4. **Do not common vent this appliance with any other vented appliance** (Do not terminate vent into a chimney. If the vent must go through the chimney, the vent must run all the way through the chimney with Category III approved or Special BH vent pipe).
5. The maximum length of exhaust vent piping must not exceed 50 ft. deducting 5 ft. for each elbow used in the venting system. Do not use more than 5 elbows.

Diameter	Max. No. of Elbow	Max. Vertical or Horizontal run in Length
4"	5 Ea.	50 ft

***For each elbow added, deduct 5 ft. from max. vent length.**

No. of Elbows	Max. Vertical or Horizontal Length
0	50 ft.
1	45 ft.
2	40 ft.
5	25 ft.

6. When the horizontal vent run exceeds 5 ft., support the vent run at 3 ft. intervals with overhead hangars.
7. The manufacturer will not be responsible for any damage to the water heater caused by condensation from the vent. Installing a condensate drip is recommended. Please refer to p. 13 for the diagrams.



When installing the vent system, all applicable national and local codes must be followed. If you install thimbles, fire stops or other protective devices and they penetrate any combustible or noncombustible construction, be sure to follow all applicable national and local codes.

VENT TERMINATION



WARNING: Improper installation can cause nausea or asphyxiation, severe injury or death from carbon monoxide and flue gases poisoning. Improper installation will void product warranty.

- The vent terminator provides a means of installing vent pipe through the building wall and must be located in accordance with ANSI Z223.1/NFPA 54, or in Canada with CAN/CSA-B149.1 and local applicable codes.
- A proper sidewall vent terminator is recommended when the water heater is vented through a sidewall. If the 710 is converted to a direct-vent unit, a proper sidewall direct-vent terminator is to be used.

General rules for venting the 710 water heater are:

1. Place the water heater as close as possible to the vent terminator.
2. The vent collar of the water heater must be fastened directly to an unobstructed vent pipe.
3. Do not weld the vent pipe to the water heater collar.
4. Do not cut the vent collar of the unit.
5. The weight of the vent stack must not rest on the water heater.
6. The vent must be easily removable from the top of the water heater for normal service and inspection of the unit.
7. The water heater vent must not be connected to any other gas appliance or vent stack.
8. Avoid locating the water heater vent terminator near **any air intake devices**. These fans can pick up the exhaust flue products from the gas appliance and return them to the building. This can create a health hazard.
9. Avoid using an oversized vent pipe or using extremely long runs of the pipe.
10. Locate the vent terminator so that it cannot be blocked by any debris, at any time. Most codes require that the terminator be at least 12 inches above grade, but the installer may determine if it should be higher depending on the job site condition and applicable codes.
11. For rooftop venting, a rain cap must be installed.
12. **The manufacturer recommends the “T-Vent” line manufactured by TAKAGI** (Refer to the venting brochure for details). However, the following are also UL listed manufacturers: ProTech Systems Inc. (FasNSeal), Flex-L Inc., Z-Flex Inc. (Z-Vent III), Metal-Fab Inc., and Heat-Fab Inc. (Saf-T Vent).

Horizontal Installation Diagram

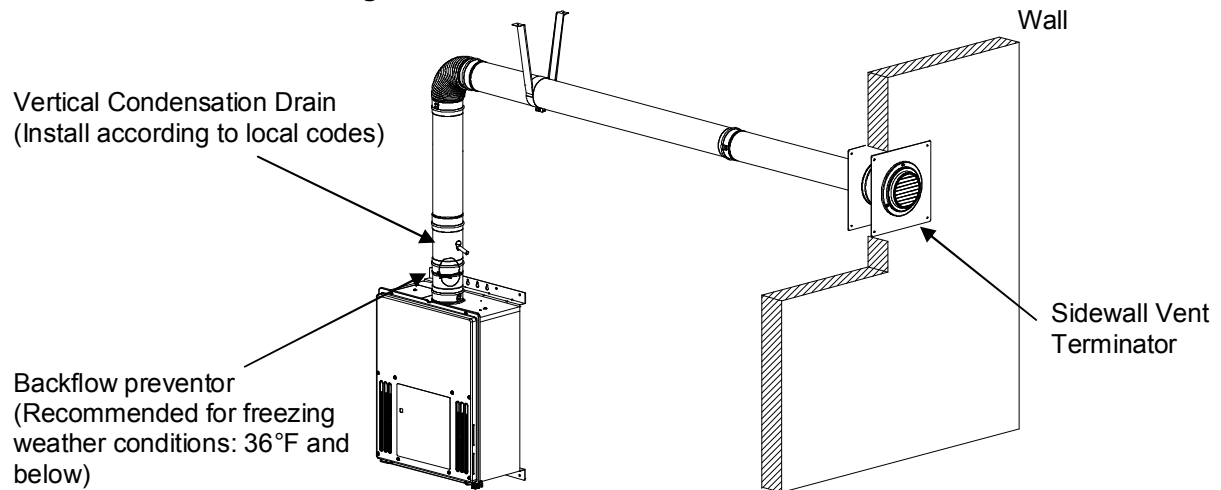

Vertical Installation Diagram

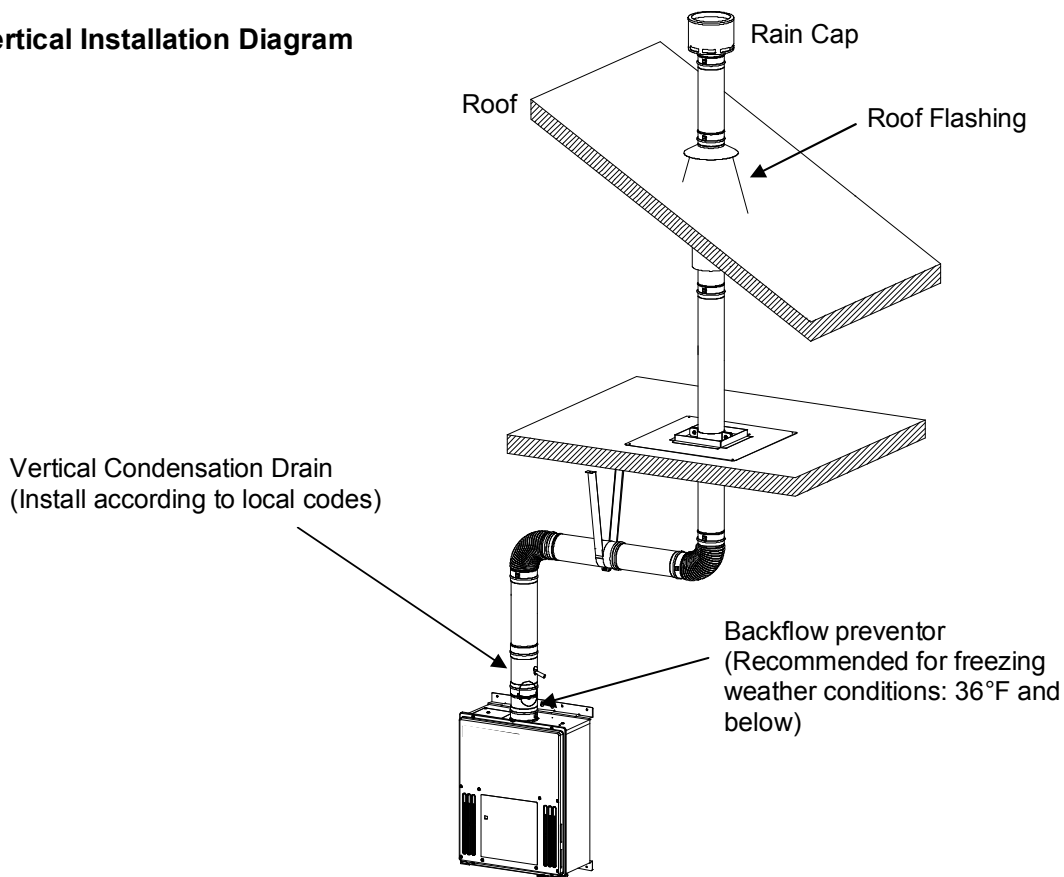

- Regarding the clearance from the terminator to the air inlet or opening, refer to the next page.
- Install a condensation drain in the venting.
- Follow the vent system to vent manufacturer's instruction and local code.
- Do not common vent or connect any vent from other appliances to the 710 vent.
- Use 4" category III approved or Special BH, single or double wall stainless steel vent pipe.

VENT CLEARANCES

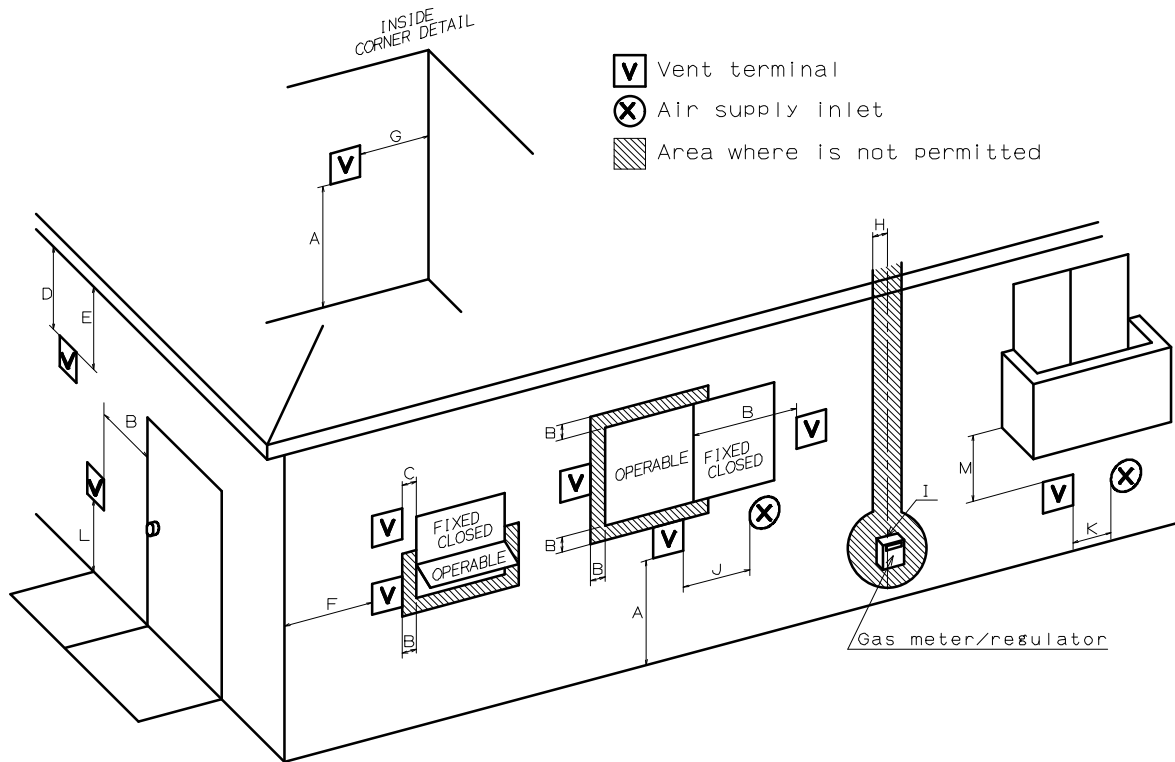

		Canada	U.S.A	
		Direct vent and other than Direct Vent	Direct vent	Other than Direct Vent
A	Clearance above grade, veranda, porch, deck, or balcony.	1 foot	1 foot	1 foot
B	Clearance to window or door that may be opened.	3 feet	1 foot	4 feet from below or side opening. 1 foot from above opening.
C	Clearance to permanently closed window	*	*	*
D	Vertical clearance to ventilated soffit located above the vent terminator within a horizontal distance of 2 feet (61cm) from the center line of the terminator.	*	*	*
E	Clearance to unventilated soffit	*	*	*
F	Clearance to outside corner	*	*	*
G	Clearance to inside corner	*	*	*
H	Clearance to each side of center line extended above meter/regulator assembly	3 feet	*	*
I	Clearance to service regulator vent outlet.	3 feet	*	*
J	Clearance to non-mechanical air supply inlet to building or the combustion air inlet to any other application.	3 feet	1 foot	4 feet from below or side opening. 1 foot from above opening.
K	Clearance to mechanical air supply inlet.	6 feet	3 feet	3 feet
L	Clearance above paved sidewalk or paved driveway located on public property.	7 feet	*	7 feet
M	Clearance under veranda, porch deck, or balcony.	1 foot	*	*

*For clearances not specified in ANSI Z223.1 / NFPA 54 or CAN/CSA-B149.1, please use clearances in accordance with local installation codes and the requirement of the gas supplier.

GAS SUPPLY AND GAS PIPE SIZING

TO TURN OFF GAS TO APPLIANCE

1. Turn off all electric power to the water heater if service is to be performed.
2. Turn the manual gas valve located on the outside of the unit clockwise \odot to the off position.



WARNING: Conversion of this unit from natural gas to propane or vice versa will void all warranty. Contact your local distributor to get the correct unit for your gas type. **The manufacturer is not liable for any property and/or personal damage resulting from gas conversions.**

***Check that the type of gas matches the rating plate first.**

1. The minimum and maximum inlet gas pressures are:

Natural Gas	Min. 5.0" WC - Max. 10.5" WC
Propane Gas	Min. 8.0" WC - Max. 14.0" WC

2. Gas pressure below this specified range for the 710 and/or insufficient gas volume will adversely affect performance. These pressures are measured when the 710 is in full operation.
3. Inlet gas pressure must not exceed the above maximum values; gas pressure above the specified range will cause dangerous operating conditions and damage to the unit. Ensure that any and all gas regulators used are operating properly and are providing gas pressures within the specified range shown above.
4. Until testing of the main gas line supply pressure is completed, ensure the gas line to the 710 is disconnected to avoid any damage to the water heater.

MEASURING INLET GAS PRESSURE

The 710 cannot perform properly without sufficient inlet gas pressure. Below are instructions on how to check the inlet gas pressure. **THIS IS ONLY TO BE DONE BY A LICENSED PROFESSIONAL.**

1. Shut off the manual gas valve on the supply gas line.
2. Open a faucet. The unit should turn on and the gas in the gas pipe line should purge. Leave the faucet on to keep the unit running until the unit shut down due to lack of gas supply. Then shut the faucet off.
3. Remove the screw for the pressure port located on the gas inlet of the 710 shown in the diagram to the right.
4. Connect the manometer to the pressure port.
5. Re-open the manual gas valve. Check to see that there are no gas leaks.
6. Open some of the fixtures that use the highest flow rate to turn on the 710.
7. Check the inlet gas pressure. When 710 is on a maximum burn, the manometer should read from 5.0" to 10.5" WC for Natural gas, from 8.0" to 14.0" WC for Liquid Propane.

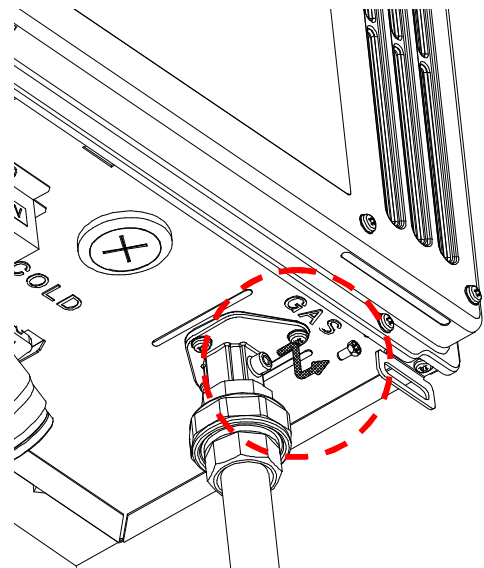



Size the gas pipe appropriately to supply the necessary volume of gas required for the 710 (240,000 BTU/H for Natural Gas or 240,000 BTU/H for Liquid Propane) using ANSI233.1/NAPA 54 in the USA or CAN/CSA B149.1 in Canada or local codes. Otherwise, flow capabilities and output temperatures will be limited.

1. Install a manual gas shut-off valve between the 710 and the gas supply line.
2. When the gas connections are completed, it is necessary to perform a gas leak test either by applying soapy water to all gas fittings and observing for bubbles or by using a gas leak detection device.
3. Always purge the gas line of any debris and/or water before connecting to the gas inlet.

Natural Gas Supply Piping

Maximum Delivery Capacity of Cubic Feet of Gas per Hour of IPS Pipe Carrying Natural Gas of 0.60 Specific Gravity Based on Pressure Drop of 0.5" WC

Based on Energy Content of 1,000 BTU/Cubic Ft.: 710 requires 240 Cubic Ft./hr. Unit: Cubic Feet per Hour

Pipe Size	Length of Pipe												
	10'	20'	30'	40'	50'	60'	70'	80'	90'	100'	125'	150'	200'
3/4"	363	249	200	171	152	138	127	118	111	104	93	84	72
1"	684	470	377	323	286	259	239	222	208	197	174	158	135
1 1/4"	1,404	965	775	663	588	532	490	456	428	404	358	324	278
1 1/2"	2,103	1,445	1,161	993	880	798	734	683	641	605	536	486	416
2"	4,050	2,784	2,235	1,913	1,696	1,536	1,413	1,315	1,234	1,165	1,033	936	801
2 1/2"	6,455	4,437	3,563	3,049	2,703	2,449	2,253	2,096	1,966	1,857	1,646	1,492	1,277
3"	11,412	7,843	6,299	5,391	4,778	4,329	3,983	3,705	3,476	3,284	2,910	2,637	2,257

Propane (LP) Gas Supply Piping

Maximum Capacity of Propane (LP) Gas Based on 11" WC supply pressure at a 1.0" WC pressure drop

Unit: kBtu per Hour

Pipe Size	Length in Feet												
	inches	10'	20'	30'	40'	50'	60'	70'	80'	90'	100'	125'	150'
3/4"	567	393	315	267	237	217	196	185	173	162	146	132	112
1"	1,071	732	590	504	448	409	378	346	322	307	275	252	213
1 1/4"	2,205	1,496	1,212	1,039	913	834	771	724	677	630	567	511	440
1 1/2"	3,307	2,299	1,858	1,559	1,417	1,275	1,181	1,086	1,023	976	866	787	675
2"	6,221	4,331	3,465	2,992	2,646	2,394	2,205	2,047	1,921	1,811	1,606	1,496	1,260

Gas Sizing Example (Natural Gas)

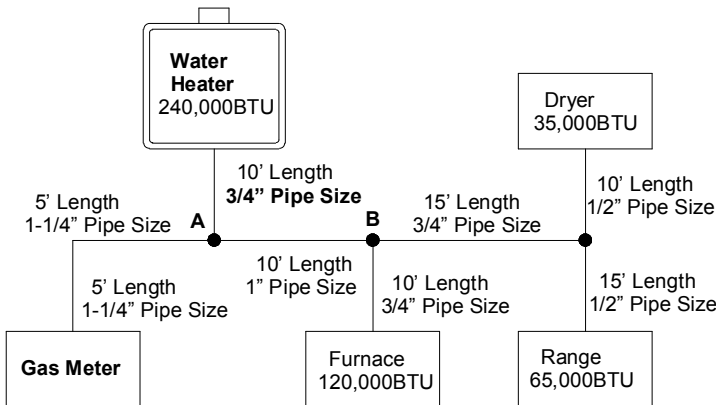

Based on Energy Content of 1,000BTU/Cubic Ft:

Divide each appliance's BTU requirement by 1,000BTU to get the appliances Cubic Ft. requirement.

Take into account the distance the appliance is from the gas meter, look in the above gas chart to properly size the line.

For sections of the gas line supplying gas to more than one appliance (Ex: Point A to Point B), add up the cubic ft. requirements of the appliances that are being supplied by that section, and size to the farthest appliance.

For Example: The section from A to B supplies gas to the furnace, range, and dryer. Adding up the BTU requirements and dividing by 1,000 yields a cubic ft. requirement of 220 cubic ft. of gas. The farthest appliance is the range, which is 50 ft. away from the meter. Looking at the above chart, and under the column of 50ft., Section A to B needs to be 1" in order to supply 220 cubic ft.

WATER CONNECTIONS

FOR YOUR SAFETY, READ BEFORE OPERATING:

Do not use this water heater if any part has been submersed under water. Immediately call a licensed professional to inspect the water heater and to replace any damaged parts.

1. All pipes, pipe fittings, valves and other components, including soldering materials, must be suitable for potable water systems.
2. A manual shut off valve must be installed on the cold water inlet to the water heater between the main water supply line and the 710.
3. In addition, a manual shut off valve is also recommended on the hot water outlet of the unit. If the 710 is installed within, or subjected to, a closed loop water system, a thermal expansion tank must be installed.
4. **Before installing the water heater, flush the water line to remove all debris, and after installation is complete, purge the air from the line. Failure to do so may cause damage to the heater.**
5. There is a wire mesh filter within the cold inlet to trap debris from entering your heater. This will need to be cleaned periodically to maintain optimum flow.



CAUTION: Do not reverse the hot outlet and cold inlet connections to the 710 Water Heater. This will not activate the water heater.

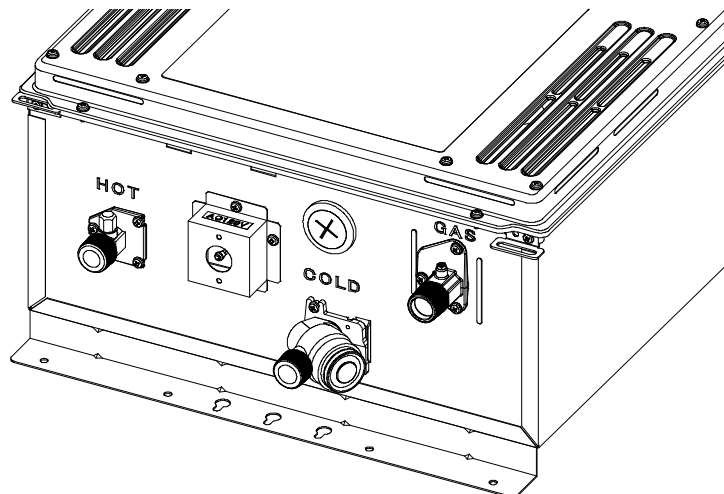

PRESSURE RELIEF VALVE

The 710 has a high-temperature shut-off switch built in as a standard safety feature (called a Hi-Limit switch) therefore a “**pressure only**” relief valve is required.

1. This unit does not come with an approved pressure relief valve.
2. An approved pressure relief valve must be installed on the hot water outlet.
3. The pressure relief valve must conform to ANSI Z21.22 or CAN 1-4.4 and installation must follow local code.
4. The discharge capacity must be at least 240,000 BTU/h.
5. The pressure relief valve needs to be rated for a maximum of 150 psi.
6. The discharge piping for the pressure relief valve must be directed so that the hot water cannot splash on anyone or on nearby equipment.
7. Attach the discharge tube to the pressure relief valve and run the end of the tube to within 6" from the floor. This discharge tube must allow free and complete drainage without any restrictions.
8. If the pressure relief valve installed on the 710 discharges periodically, this may be due to a defective thermal expansion tank or defective pressure relief valve.
9. The pressure relief valve must be manually operated periodically to check for correct operation.
10. For the ASME model, the pressure relief valve must conform to and be installed in accordance with ASME code.

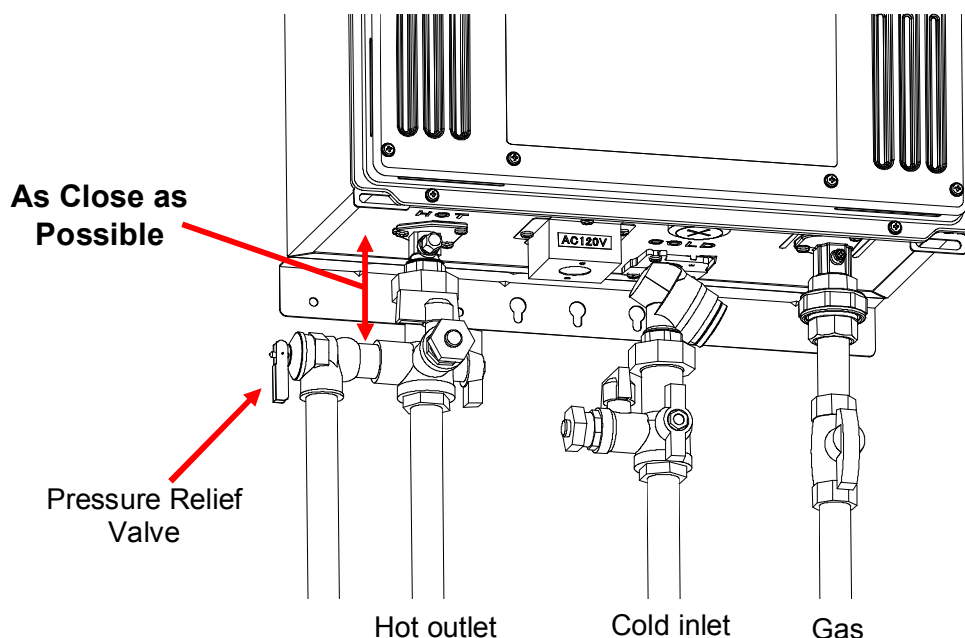

ELECTRICAL CONNECTIONS

WARNING: Follow the electrical code requirements of the local authority having jurisdiction. In the absence of such requirements, follow the latest edition of the National Electrical Code ANSI/NFPA 70 in the U.S. or the latest edition of CSA C22.1 Canadian Electrical Code, Part 1, in Canada.

CAUTION: When servicing or replacing parts within the 710, label all wires prior to disconnection to facilitate an easy and error free reconnection. Wiring errors can cause improper and dangerous operation. Verify proper operation after servicing.

1. The heater must be electrically grounded. Do not attach the ground wire to either the gas or the water piping.
2. The 710 water heater requires **120 VAC / 60 Hz electrical power supply that is properly grounded.**
 - A proper disconnect (i.e. on/off switch, power plug, etc.) controlling the main power to the 710 must be provided for service reasons. (Must comply with local codes).
 - Connect the power supply to the 710 exactly as shown in the wiring diagram;
3. A green screw is provided in the junction box to ground the connection.
4. Can be hardwired or wired to a plug-in.
5. The use of a surge protector is recommended in order to protect the unit from power surges.

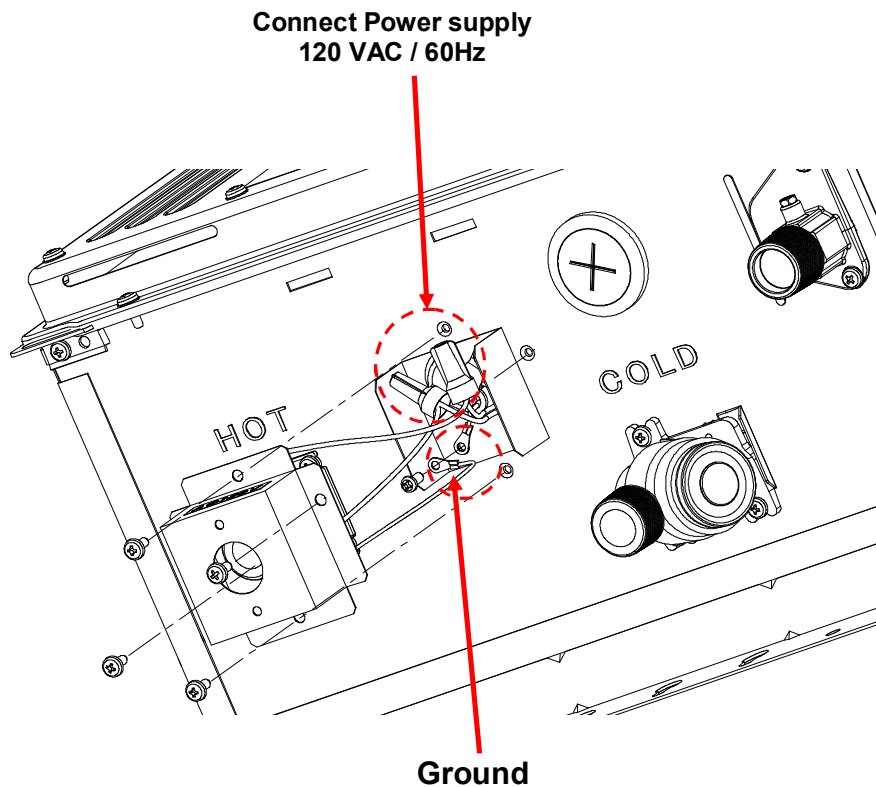

REMOTE CONTROLLER CONNECTIONS

- 1) Disconnect power supply from the water heater.
- 2) Take off the water heater's front cover.
- 3) Please find the remote control terminal using the picture below (located around the lower right-hand side of the water heater).
- 4) Open the plastic cover of the remote controller accessory, and then attach the fork terminal to the connector base of the backside the remote controller accessory with two screws. Make sure the terminals are firmly fixed.
- 5) Put the remote wires through the hole on the bottom of the unit casing.
- 6) Connect the remote wires to the remote controller terminal properly. (No polarity)
- *Do NOT jump or short-circuit wires. Computer will be damaged.**
- 7) Replace Front Cover securely.
- 8) Wires used for the remote controller connection must be:
 - Minimum 18AWG wire (No polarity)
 - Maximum 400 feet long

*For details on the connection to the remote controller accessory, refer to the remote controller Installation Manual.

Remote controller terminal inside water heater

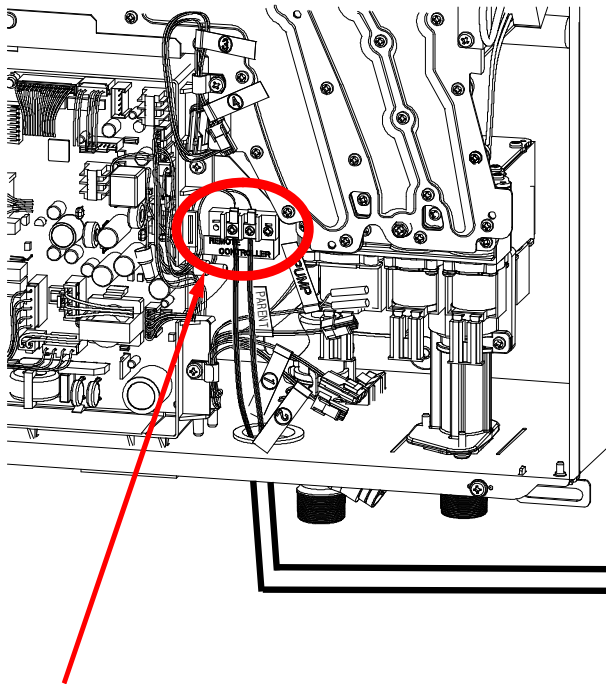

Connect to these terminals

Front of remote

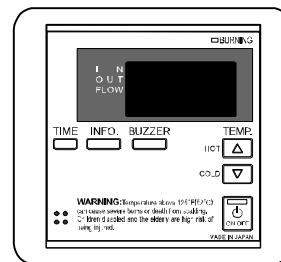

Back of remote

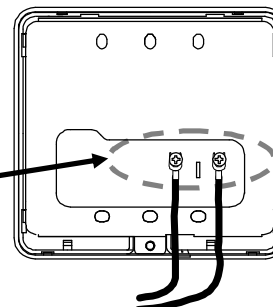

Connect other end to these terminals

PUMP CONTROL MODE

The 710 can be used to control a recirculation pump. **Proper pump control helps to preserve the life of the system and saves energy as well.**

The water heater pump control port is a “normally-open dry contact”, and therefore needs additional components to properly control a recirculation pump. To control a recirculation pump, connect the pump to the “**Pump connector**” in the water heater as shown in the diagram below. (In a multi-unit system, connect the pump **ONLY** to the “**PARENT**” unit.) The pump is to be connected using suitable relays shown in the diagram below.

Please make sure the relays are properly rated for the recirculation pump.

Using the water heater’s internal thermistors as a temperature control, the recirculation pump will only turn on when recirculation is needed.



CAUTION: In a multi-unit system, the pump must be connected to the “**Pump**” connector in the “**PARENT**” unit only. If the pump is connected to any of the “**CHILD**” units, the pump will not work.

These components are **NOT** included with water heaters and are external to the unit. They must be acquired separately.

Connect to this “Pump connector”.

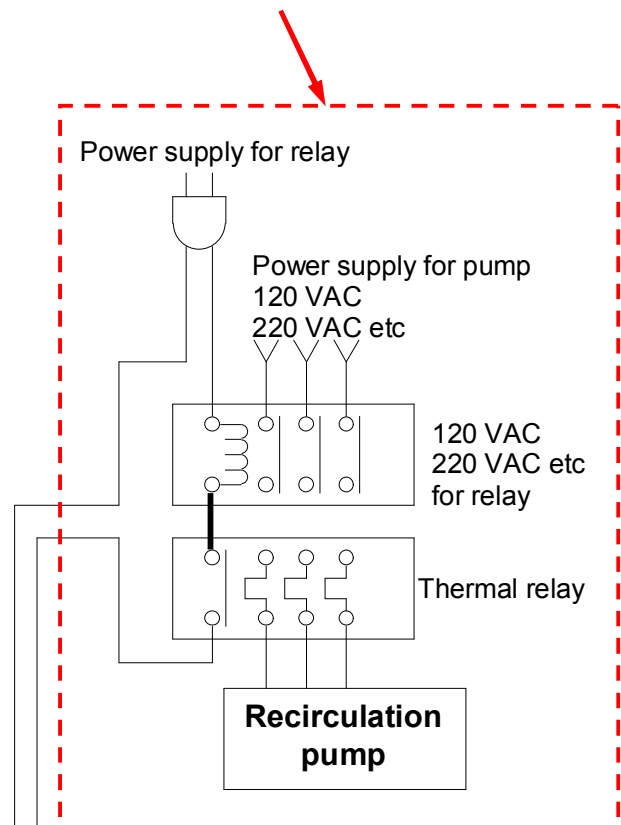
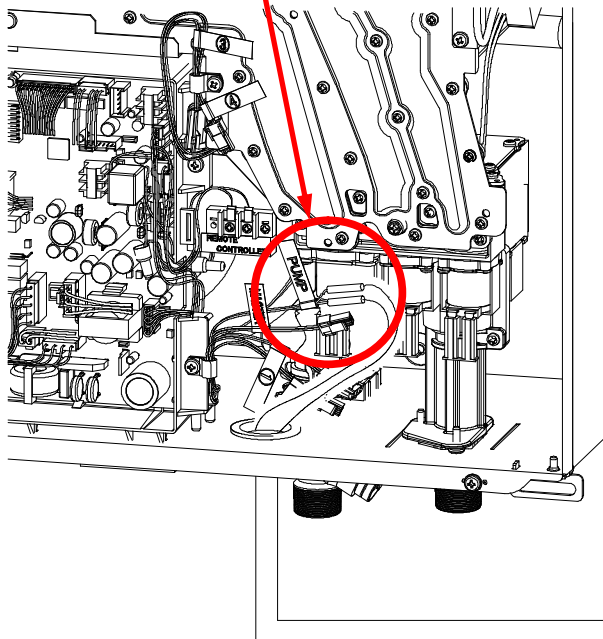

PUMP CONTROL MODE

The 710 provides the four types of the pump control modes. The pump control modes are selected by changing dipswitch settings. The dipswitches are located in the **right bank** of dipswitches in the upper-left quadrant of the computer board in the 710. (See the next page)

A) Recirculation Control: No. 6 ON

Feature: Water heaters can provide hot water as soon as possible like a recirculation usage.

Function: The pump is set only to run when the temperature of the water in the re-circulation loop is much lower than the set temperature of the 710.

The pump will run for about 1 minute in every 30 minutes to determine whether the water temperature in the whole recirculation loop is lower than 9°F from the set temperature or not. If the water temperature is lower than 9°F from the set temperature, the pump will remain running until the water in the loop reach the set temperature. Otherwise, the pump will stop for another 30 minutes.

If the inlet thermistor of water heaters detects that the water temperature is lower than 9°F from the set temperature before those 30 minutes have elapsed, the pump will activate immediately and remain running until the water in the loop reach the set temperature.

Note: The recirculation pump needs to be connected to the pump terminal of the 710.

B) Storage Tank Circulation Control: No.7 ON

Feature: This is to ensure a higher rate of recovery for storage tank applications.

Function: The 710 makes Water heaters heat the water 5.4°F higher than its set temperature. The circulation pump (from storage tank to Water heaters) will always remain on. After hot water temperature reach the temperature above, the 710 makes the Water heaters to adjust the water flow to be less than 2.6 GPM, in order to detect temperature in the system.

Note: In this mode, the 710 will not provide the pump control. The termination of the pump is kept ON position continually.

C) Energy Conserving Recirculation: No.6 and No.7 ON

Feature: Save Energy Mode in Recirculation Control by keeping the water temperature in the loop system hot during circulation with Recirculation Control and Pump Control, so it will cut down the cost of the gas and electricity.

Function: Energy Conserving Recirculation and the Pump Control is similar to the "Recirculation Control" explained above. The hot water temperature in the loop during recirculation is kept at maximum 122°F (50 °C) even if the set temperature of 710 is 130°F (55°C) or above.

Note: The recirculation pump needs to be connected to the pump terminal of the 710.

D) Normal Control (Default setting): No.6 and No.7 OFF:

Feature: This mode provides no special pump control. The pump operation can only be turned ON and OFF by the remote controller.

Function: If a pump is connected to the pump control terminal and both No.6 and No.7 are OFF, the pump will be made to run all the time as long as there is a power supply to the 710. The pump will stop when the remote controller is turned off. Water in the loop will be maintained at set temperature.

Dipswitch settings for the Pump control mode

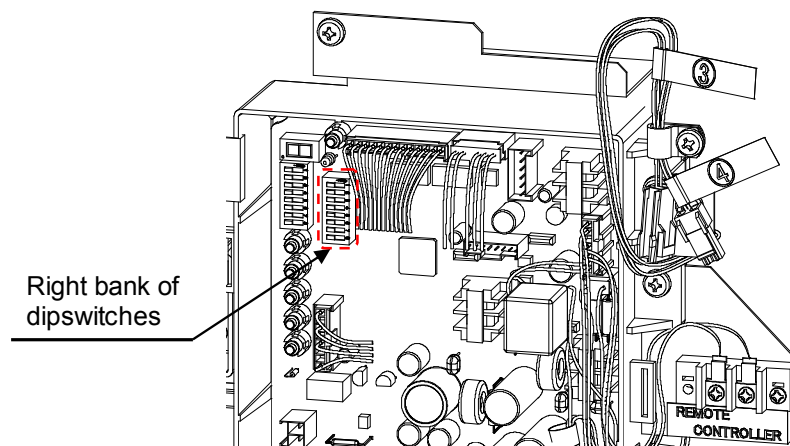

Right bank of dipswitches	A) Recirculation Control	B) Storage Tank Circulation Control	C) Energy Conserving Recirculation	D) Normal Control (Default)

The dark squares indicate the direction the dipswitches should be set to.

EASY-LINK SYSTEM

The 710 can be connected with other heaters of the **same model** with communication cables to work as a multiple manifold system.

- The Easy-Link system can connect up to 4 units.
- A communication cable (gray color) comes with each unit. The cables use 18 gage wire and can be up to 250ft. long all together.

You can manifold from 2 units to 4 units without a multi-system controller. A 4-unit system has full automatic modulation between 24,000 BTU/h and 960,000 BTU/h.

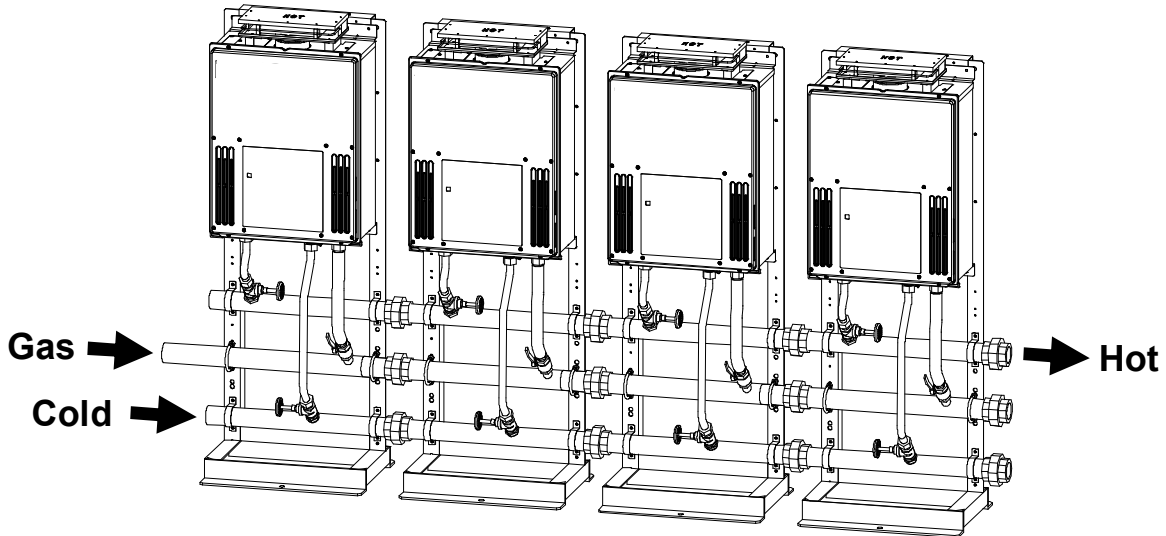

CAUTION

- The Easy-Link system is limited to **4 units**. If you connect more than 4 units, the first 4 units will work as part of the Easy-Link system, but the other additional units will only work as individual units.
- **The 710 cannot be linked with other different models in the Easy-Link system.**

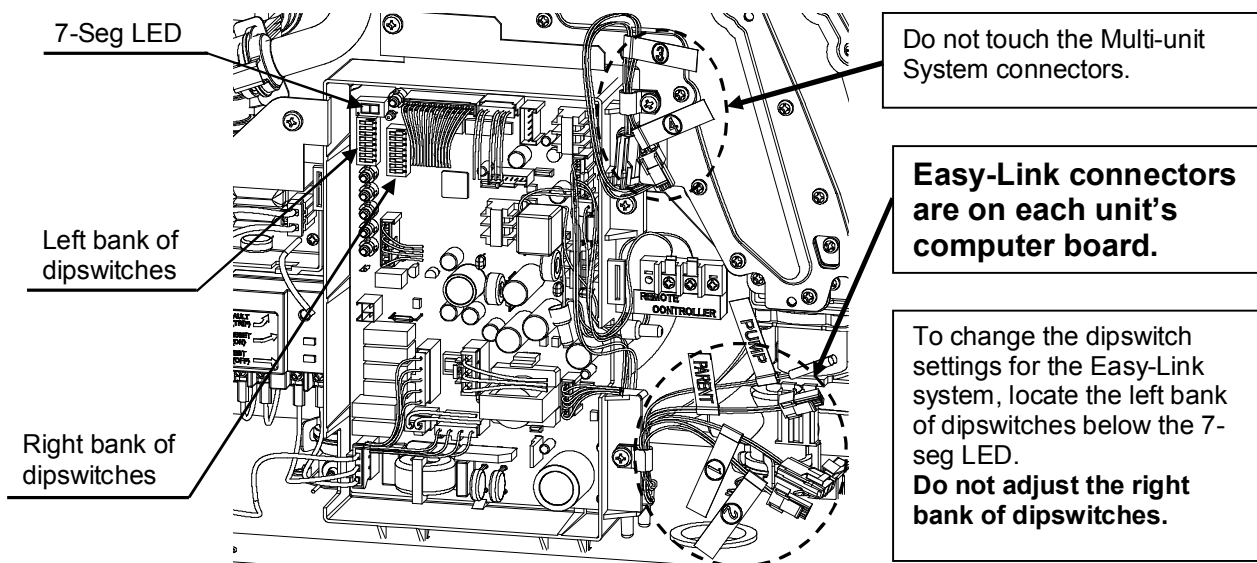

Easy-Link Connection Procedures

1. Choose one of your units as the “**PARENT**” unit.

2. “The PARENT”

Locate the **left bank** of dipswitches to the lower of the 7-seg. LED on the computer board of the unit that you select to be the “**PARENT**” unit. Change dipswitch No. 8 to “**ON**”. Do not change any of the dipswitches on the “**CHILD**” units.

3. Between the “PARENT” and the “CHILD-1”

Connect the “**PARENT**” connector of the “**PARENT**” unit to the “[**1**]” connector of the “**CHILD-1**” unit.

4. Between the “CHILD-1” and the “CHILD-2”

Connect the “[**2**]” connector of the “**CHILD-1**” unit to the “[**1**]” connector of the “**CHILD-2**” unit.

5. Between the “CHILD-2” and the “CHILD-3”

Connect the “[**2**]” connector of the “**CHILD-2**” unit to the “[**1**]” connector of the “**CHILD-3**” unit.

6. Make sure the “7-seg LED” of all the units’ computer boards display the unit #. The numbering system of the 710 automatically allocates the unit # to each water heater that is part of the Easy-Link system.

PARENT unit	Unit # : 1
CHILD units	Unit# : 2, 3 and 4

The dark squares indicate the direction the dipswitches should be set to.

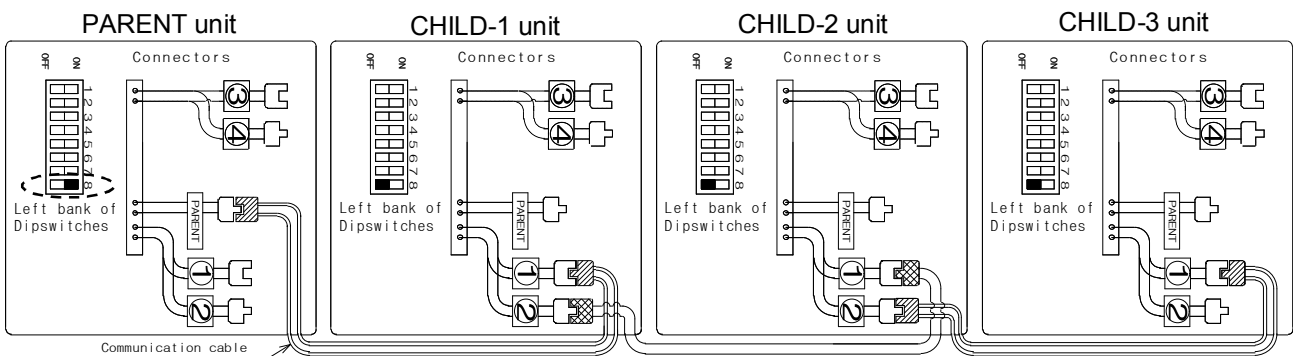

CAUTION

- Unless you change dipswitch No. 8 of the “**PARENT**” unit to “**ON**”, the system will not work as an Easy-Link system. The units will work as individual units.



Wrong dipswitch setting on the “**PARENT**” unit

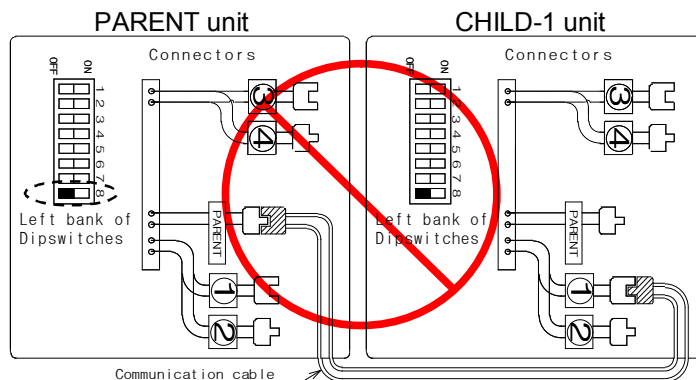

CAUTION

- If you connect the “[1] (or [2])” connector of the “PARENT” unit to the “PARENT (or [1])” connector of the “CHILD-1” unit, the system will not work as the easy-link system. The units will work as individual units.

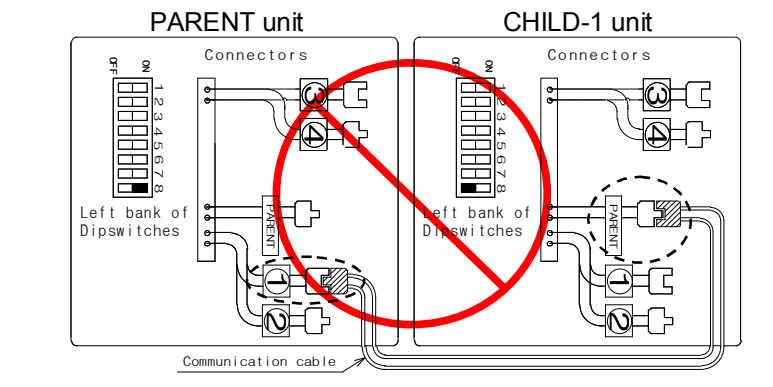

Wrong connection between the “PARENT” unit and the “CHILD-1” unit

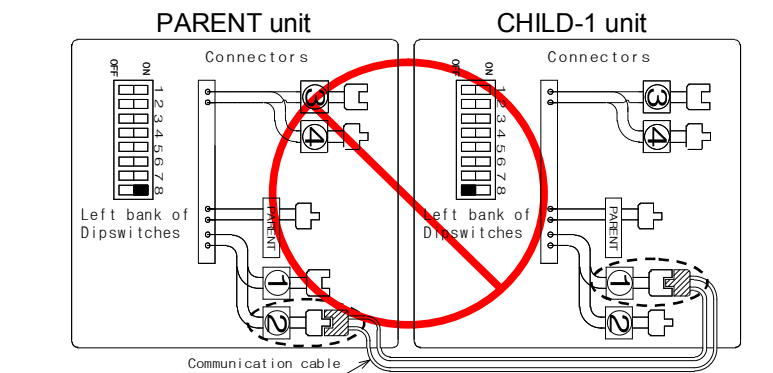

- If a remote controller (optional) is used, it has to be connected to the “PARENT” unit. If the remote controller is connected to a “CHILD” unit, it will only control that particular individual “CHILD” unit and will not control the Easy-Link system as a whole.



Wrong connection between the “CHILD” unit and the remote controller

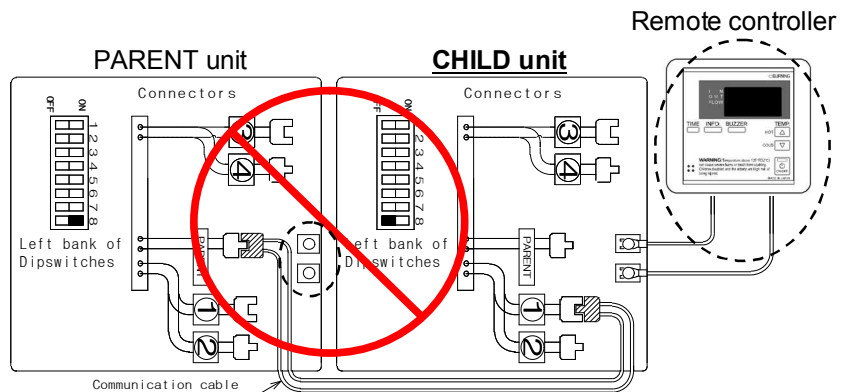

- The remote controller is not required for the Easy-Link system.
- If running the Easy-Link system without the remote controller, please make sure the dipswitch settings for the temperature, outdoor, and direct-vent settings on ALL the units are set to the same settings. Otherwise, the units may not operate properly.
- If the remote controller is used, the temperature on all the units in the system will automatically be set to the same temperature that is set on the remote. However, even with the remote, the outdoor and direct-vent dipswitch settings still need to be set to the same settings on all the units.



CAUTION

- If you connect the “PARENT” connector of the “PARENT” unit to the “[3]” connector of the “CHILD-1” unit, the “PARENT” unit and the “CHILD-1” unit will display “761” error code.

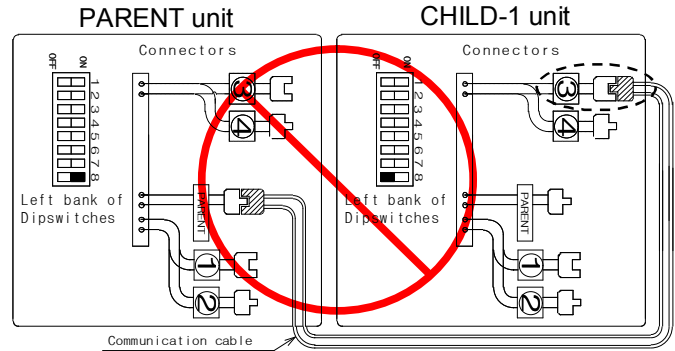

Wrong connection between the “PARENT” unit and the “CHILD-1” unit

- If you connect the “[2]” connector of the “CHILD-1” unit to the “[3]” connector of the “CHILD-2” unit, the “PARENT” unit and the “CHILD-2” unit will display “761” error code.

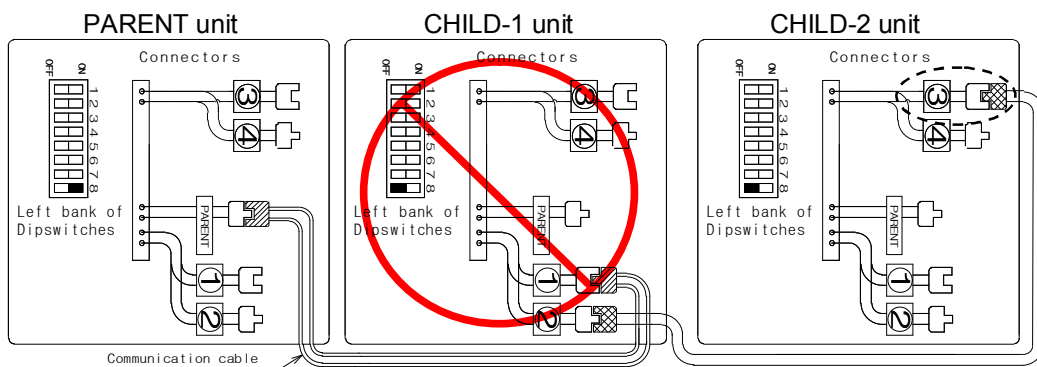

Wrong connection between the “CHILD-1” unit and the “CHILD-2” unit

- If you connect the “PARENT” connector of the “CHILD-1” unit to the “[1]” connector of the “CHILD-2” unit, the “CHILD-2” unit will work as an individual unit, and will not be part of the Easy-Link system.



Wrong connection between the “CHILD-1” unit and the “CHILD-2” unit

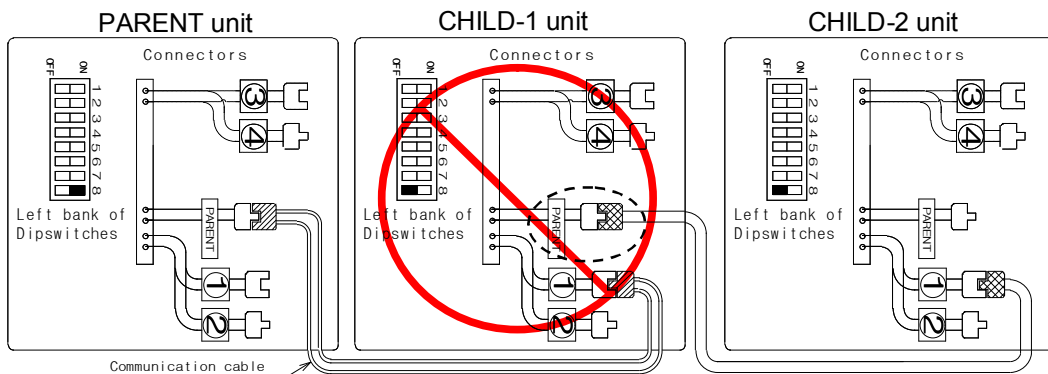

WARNING

Connecting two “PARENT” connectors together from two separate units **may damage the computer board**. The communication cable has a female end and a male end so it’s impossible to have a PARENT -to- PARENT connection with the communication cable. Do not splice or modify connectors.



Prohibited

MULTI-UNIT SYSTEM FOR LARGE VOLUMES

Multiple 710 models can be combined for a Multi-Unit system, along with the Multiple Unit Controller and Remote Controller (Parts 9007675005 and 9007603005). Each set of controllers (one 9007675005 and one 9007603005) can control from 2 units to 20 units for commercial or residential applications. For a 20-unit system, the computer can modulate between the usages of 24,000 BTU/h to 4.8 Million BTU/h.

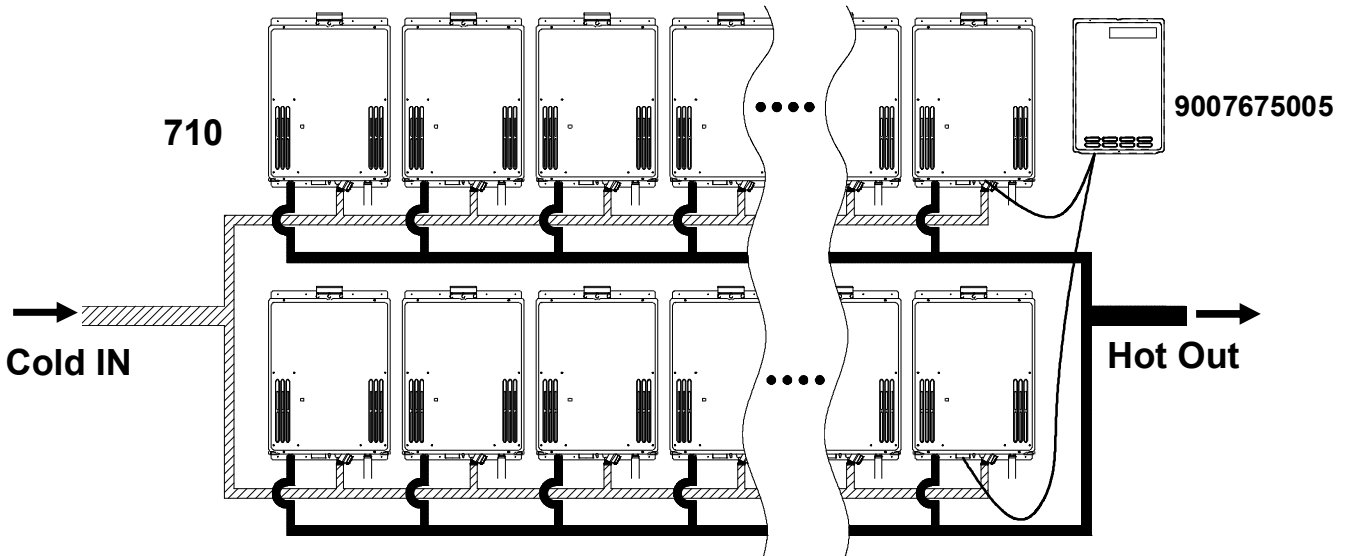

An individual cut-off switch if hard-wired is recommended for each unit in a multi-unit system for the purpose of maintenance.

Multi-Unit System Connection Diagram

Multi-Unit Controller (9007675005) and Temperature Remote Controller (9007603005) wiring:

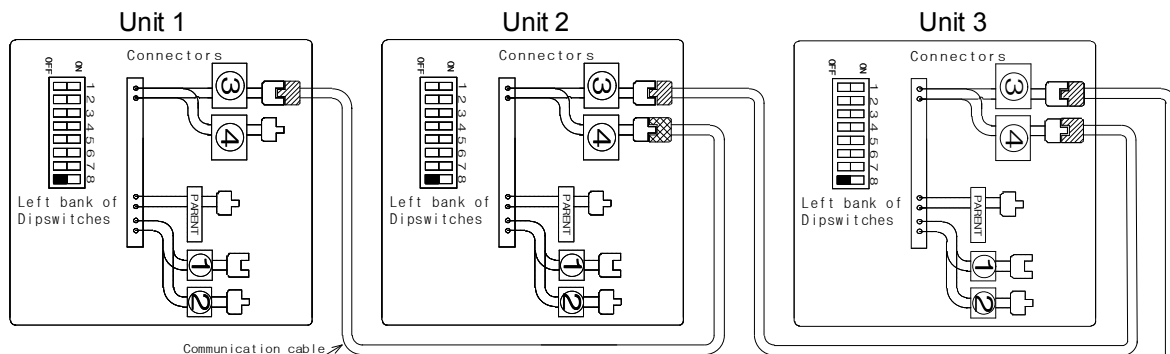

The dark squares indicate the direction the dipswitches should be set to.

This is the connection diagram between 710 and 9007675005 for 2 to 20 water heaters. As shown is a sample for 3 water heaters.

Make sure the "7-seg LED" of all the units' computer boards display the unit #. The Multi-unit controller automatically allocates the unit # (1-20) to each water heater that is part of the Multi-unit system.

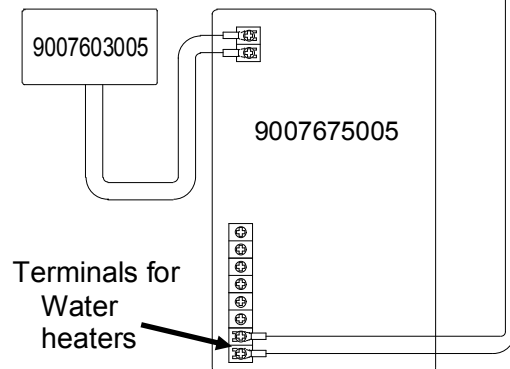

In a Multi-Unit system, connect the “[3]” connector and the “[4]” connector with the communication cable.

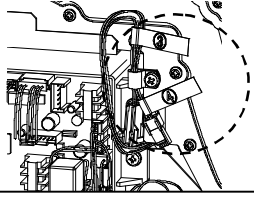

Wire [3] (Male Adapter) and [4] (Female Adapter)

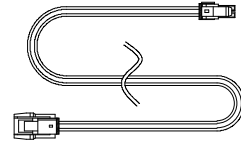

The Communication Cables are included with the 710. The Cables use 18 gage wire and can be up to 250 ft. long.

Please refer to the Multi-unit Controller manual for further instructions of the Multi-Unit system.

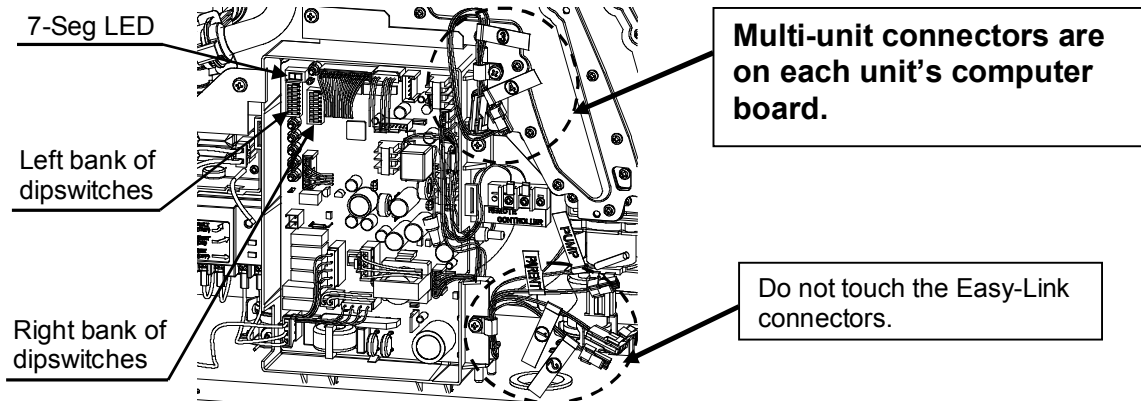





INITIAL OPERATION

FOR YOUR SAFETY, READ BEFORE OPERATING:

- **Check the GAS and WATER CONNECTIONS** for leaks before firing it for the first time.
- Open the main gas supply valve to the unit using only your hand to avoid any spark. Never use tools. If the knob will not turn by hand, do not try to force it; call a qualified service technician. Forced repair may result in a fire or explosion due to gas leaks.
- Be sure to check next to the bottom of the unit because some gases are heavier than air and may settle towards the floor.
- **Check the GAS PRESSURE.** Refer to p.15.
- Do not try to light the burner manually. It is equipped with an electronic ignition device which automatically lights the burner.
- **Check for PROPER VENTING and COMBUSTIBLE AIR** to the heater.
- **Purge the GAS and WATER LINES** to remove any air pocket.
- Do not use this water heater if any part has been submersed under water. Immediately call a qualified service technician to inspect the water heater and to replace any damaged parts.

CAUTION: IF YOU SMELL GAS:

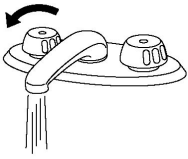
- Do not try to start the water heater.
- Do not touch any electric switch; do not use any phone in your building.
- Immediately call your gas supplier from a neighbor's phone. Follow the gas supplier's instructions.
- If you cannot reach your gas supplier, call the fire department.

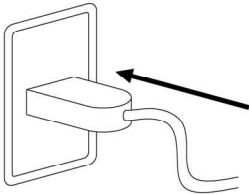
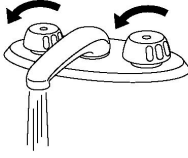
<p>1. Once the above checks have been completed, please clean filter of any debris. Refer to p. 35 for instructions.</p> <div style="text-align: center; margin-top: 20px;">  </div>	<p>2. Fully open the manual water control valve on the water supply line.</p> <div style="text-align: center; margin-top: 20px;">  </div>	<p>3. Open a hot water tap to verify that water is flowing to that tap.</p> <div style="text-align: center; margin-top: 20px;">  </div> <p style="text-align: center; margin-top: 10px;">Then close the hot water tap.</p>
<p>4. Fully open the manual gas control valve installed.</p> <div style="text-align: center; margin-top: 20px;">  </div>	<p>5. Turn on the 120 volt 60 Hz power supply to the water heater.</p> <div style="text-align: center; margin-top: 20px;">  </div>	<p>6. Now you are ready to enjoy hours of endless hot water.</p> <div style="text-align: center; margin-top: 20px;">  </div>

NORMAL OPERATION



- Flow rate to activate the 710: 0.5 gallon per minute
- Flow rate to keep the 710 running : 0.4 gallon per minute

1. NORMAL OPERATION WITHOUT REMOTE CONTROLLER

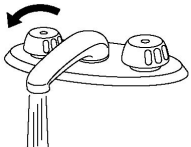
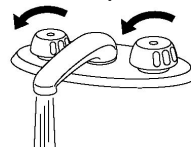
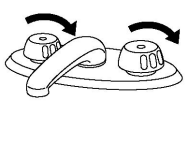
<p>1. Open a hot water tap.</p> 	<p>2. Mix cold water with the hot to get the correct temperature water.</p> 	<p>3. Close the hot water tap.</p> 
---	---	--

2. NORMAL OPERATION WITH REMOTE CONTROLLER INSTALLED: 9007603005 (Optional)

1. Press the power ON/OFF button.

2. Set temperature. (Example 110°F)

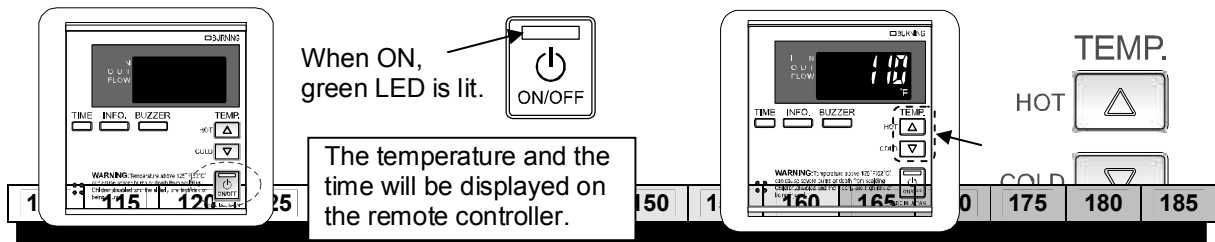

Temperatures available under the Default Mode

100	105	110	115	120	125	130	135	140	145	150	155	160	165	170	175
-----	-----	-----	-----	-----	-----	-----	-----	-----	-----	-----	-----	-----	-----	-----	-----

Temperatures available under the High Temperature Mode

DO NOT set to 185 °F if you use your water heater in recirculation system. Refer to p.34 (unit:°F)

3. Open a hot water tap.
Mix cold water with the hot if you need.

4. Close the hot water tap.

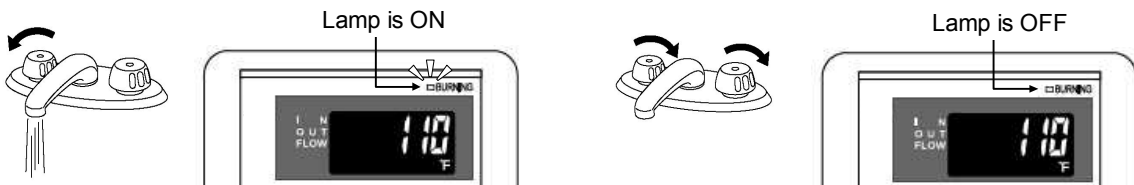

WARNING

Hot Water temperatures over 125°F (52°C) can cause severe burns instantly or death from scalding.

- The outlet hot water temperature of the 710 water heater is factory set at 120°F (49°C).
- Feel the water temperature before bathing or showering.



***To change the remote controller's mode from Default Mode to High Temperature Mode, please follow the procedures below (the remote controller must be installed prior to operating these procedures):**



DO NOT set to 185°F if you use your 710 in a recirculation system. This will cause damage to the heater and void the warranty.

1. Turn off power to the remote controller by pressing the **"ON/OFF"** button.



Lamp is OFF to indicate that power is off

2. Simultaneously press and hold both the **"HOT"** and **"COLD"** buttons for at least five seconds. And then make sure "1" (or "0") is displayed on remote controller.
 "1" is displayed for single units "0" is displayed for Easy-Link / Multi-unit Systems

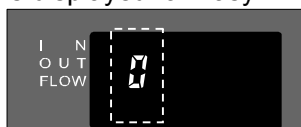

3. Press the **"TIME"** button. Make sure OFF and F1 are displayed on remote controller.

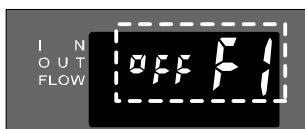

4. Press the **"INFO"** button. After, make sure "OFF" blinks.

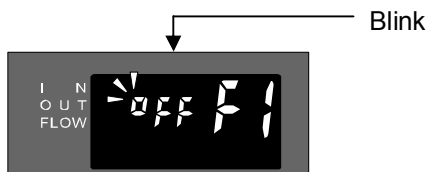

5. Press the **"HOT"** button or the **"COLD"** button to set display to "on".

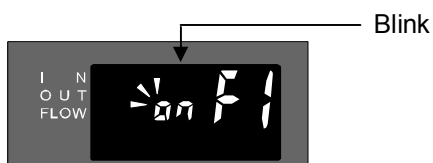

6. Simultaneously press both the **"BUZZER"** button and the **"INFO"** button to fix the setting.
7. Make sure display is no longer blinking.

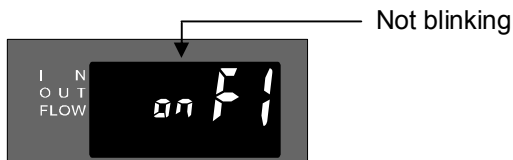

8. Press the **"ON/OFF"** button to finish the setting.
9. Turn on power to the remote controller by pressing the **"ON/OFF"** button again.



Lamp is ON

FLOW

- The flow rate through the 710 is limited to a maximum of 9.0 GPM.
- The temperature setting, along with the supply temperature of the water will determine the flow rate output of the unit.
- Please refer to the temperature vs. gallons per minute chart on p.51 to determine the likely flow rates based on your local ground water temperature and your desired outlet water temperature combination.
- Based on the United States Department of Energy method of testing water heater output, the 710 is rated for 300 gallons per hour (GPH) or 5.0 gallons per minute (GPM) for Natural Gas, and 318 GPH or 5.3 GPM for Liquid Propane, when raising the water temperature by 77°F (from 58°F to 135°F).
- Refer to the chart on the right for typical household plumbing fixture flow rates to determine what the 710 can do in a household application.

Household Flow Rates	
Appliance / Use	Flow Rate (GPM)
Lavatory Faucet	1.0
Bath Tub	4.0 – 10.0
Shower	2.0
Kitchen Sink	1.5
Dishwasher	1.5
Washing Machine	4.0

Taken from UPC 2006

FREEZE PROTECTION SYSTEM

- This unit comes equipped with heating blocks to protect it against damages associated with freezing.
- For this freeze protection system to operate there has to be electrical power to the unit. Damage to the heat exchanger caused by freezing temperatures due to power loss is not covered under the warranty. In cases where power losses can occur, consider the use of a backup power supply.
- The freeze protection system will activate when the surrounding and/or outside temperatures drop below 36.5°F (2.5°C).
- In any areas subject to freezing temperatures, the manufacturer highly recommends installing the unit indoors. In such an installation, freezing issues can only occur if cold air enters through the venting into the heat exchanger, whether by negative pressures within the installation location or by strong outside winds. It is the installer's responsibility to be aware of these issues and take all preventative measures. The manufacturer will not be responsible for any damage to the heat exchanger as a result of freezing.
- The manufacturer also highly recommends the use of a back flow vent damper and/or converting the 710 to a direct-vent unit to minimize the amount of cold air entering through the exhaust venting when the water heater is off.
- If you will not be using your heater for a long period of time:
 1. Completely drain the unit of water. Refer to p. 35.
 2. Disconnect power to your heater.
 This will keep your unit from freezing and being damaged.

CAUTION: Only pipes within the water heater are protected by the freeze protection system. Any water pipes (hot or cold) located outside the unit will not be protected. Properly protect and insulate these pipes from freezing.

TEMPERATURE SETTINGS

- There are 8 preset temperatures that you can select from by changing the dipswitch settings on the computer board.
- The temperature has been preset at the factory to 120°F (49°C).
- If you desire to change the set temperature with dipswitches, please refer to the diagram on below. These temperatures are available: 100°F, 115°F, 120°F, 135°F, 145°F, 155°F, 165°F, and 185°F.
- If you desire a hot water temperature other than the 8 preset settings, please purchase the optional temperature remote controller (part No. 9007603005).
- With this optional remote controller you can set the temperature from 100°F to 185°F with various increments.
- Please read the instructions carefully prior to installing the remote controller, as failure to do so could damage the temperature controller and/or the water heater, which will void the warranty.



- Turn off the power supply to the heater before changing the dipswitch settings.
- Only change the switches with the dark squares. The dark squares indicate which direction the dipswitch should be set to.
- DO NOT set to 185 °F if you use your water heater in a recirculation system. This will cause damage to the heater and void the warranty.

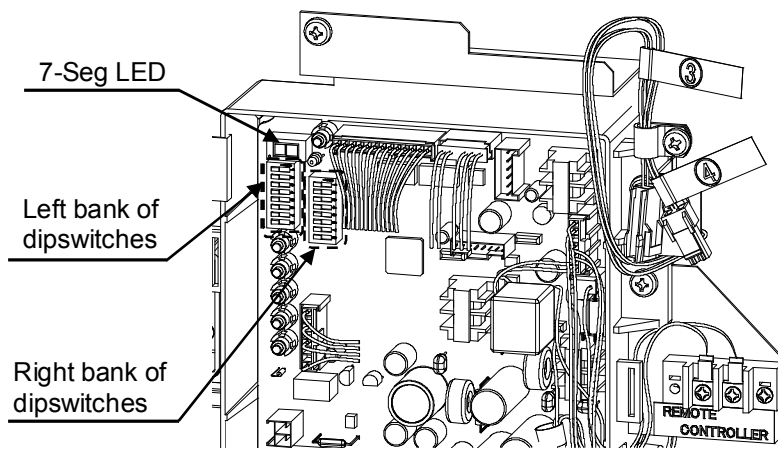

To change dipswitch settings for temperatures, locate the left bank of dipswitches the lower of 7-Seg LED. DO NOT adjust the right bank of dipswitches.

The dark squares indicate the direction the dipswitches should be set to.

Temperature Settings <Left bank of dipswitches>							
100 °F (38 °C)	115 °F (46 °C)	120 °F (49 °C) Default	135 °F (57 °C)	145 °F (63 °C)	155 °F (68 °C)	165 °F (74 °C)	185 °F (85 °C)

MAINTENANCE AND SERVICE



WARNING: Turn off the electrical power supply and close the manual gas control valve and the manual water control valve before servicing.

- Clean the cold-water inlet filter. (Refer to diagram below)
- Be sure that all openings for combustion and ventilation air are not blocked.
- Check that the exhaust vent pipe is not blocked.
- Check the gas pressure.
- Keep the area around the water heater clear. Remove any combustible materials, gasoline or any flammable vapors and liquids.

The manufacturer recommends having the unit checked once a year or as necessary by a licensed technician. If repairs are needed, any repairs should be done by a licensed technician.

UNIT DRAINING and FILTER CLEANING

1. Close the manual gas shut off valve.
2. Turn off power to the unit, and then turn on again.
3. Wait 30 seconds, and then turn off power to the unit, yet again.
4. Close the water shut off valve.
5. Open all hot water taps in the house. When the residual water flow has ceased, close all hot water taps.
6. Have a bucket or pan to catch the water from the unit's drain plugs. **Unscrew** the drain plugs to drain all the water out of the unit.
7. Wait a few minutes to ensure all water has completely drained from unit.
8. **Clean the filter:** Check the water filter located within the cold inlet. With a tiny brush, clean the water filter of any debris which may have accumulated and reinsert the filter back into the cold water inlet.
9. Securely screw the drain plugs back into place. **Hand-tighten only.**

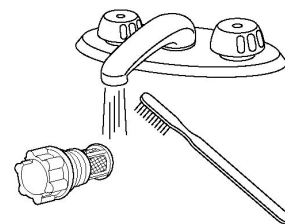
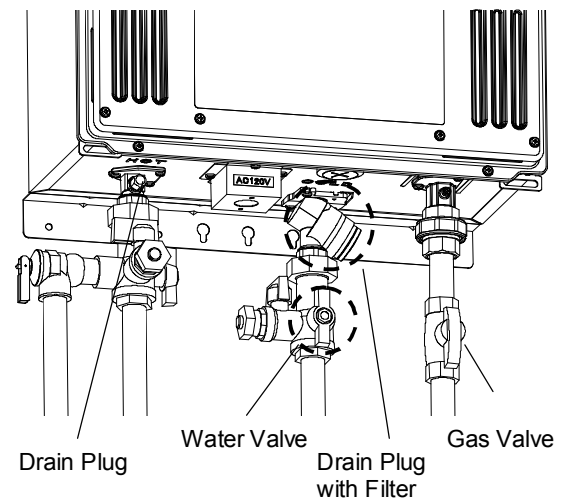

GENERAL TROUBLESHOOTING

~ TEMPERATURE and AMOUNT OF HOT WATER ~	
PROBLEM	POSSIBLE SOLUTIONS
It takes long time to get hot water at the fixtures.	<ul style="list-style-type: none"> • The time it takes to deliver hot water from the water heater to your fixtures depends on the length of piping between the two. The longer the distance or the bigger the pipes, the longer it will take to get hot water. • If you would like to receive hot water to your fixtures quicker, you may want to consider a hot water recirculation system. (p. 42)
The water is not hot enough.	<ul style="list-style-type: none"> • Compare the flow and temperature. See the chart on p. 51. • Check cross plumbing between cold water lines and hot water lines. • Is the gas supply valve fully open? (p. 30) • Is the gas line sized properly? (p. 16) • Is the gas supply pressure enough? (p. 15) • Is the set temperature set too low? (p. 31,34)
The water is too hot.	<ul style="list-style-type: none"> • Is the set temperature set too high? (p. 31,34)
The hot water is not available when a fixture is opened.	<ul style="list-style-type: none"> • Make sure the unit has 120 VAC / 60Hz power supply. • If you are using the remote controller, is the power button turned on? (p. 31) • Is the gas supply valve fully open? (p. 30) • Is the water supply valve fully open? (p. 30) • Is the filter on cold water inlet clean? (p. 35) • Is the hot water fixture sufficiently open to draw at least 0.5 GPM through the water heater? (p. 31) • Is the unit frozen? • Is there enough gas in the tank? (for LP)
The hot water gets cold and stays cold.	<ul style="list-style-type: none"> • Is the flow rate enough to keep the water heater running? (p. 31) • If there is a recirculation system installed, does the recirculation line have enough check valves? • Is the gas supply valve fully open? (p. 30) • Is the filter on cold water inlet clean? (p. 35) • Are the fixtures clean of debris and obstructions?
Fluctuation in hot water temperature.	<ul style="list-style-type: none"> • Is the filter on cold water inlet clean? (p. 35) • Is the gas line sized properly? (p. 16) • Is the supply gas pressure enough? (p. 15) • Check for cross connection between cold water lines and hot water lines.

~ WATER HEATER ~

PROBLEM	POSSIBLE SOLUTIONS
Unit does not ignite when water goes through the unit.	<ul style="list-style-type: none"> • Is the flow rate over 0.5 GPM? (p. 31) • Check for the filter on cold water inlet. (p. 35) • Check for reverse connection and cross connection. • If you use the remote controller, is the power button turned on? (p. 31)
The fan motor is still spinning after operation has stopped.	<ul style="list-style-type: none"> • This is normal. After operation has stopped, the fan motor keeps running for 35 seconds in order to re-ignite quickly, as well as push all exhaust gas out of the flue.
Abnormal sounds come from the unit.	<ul style="list-style-type: none"> • Contact the manufacturer at 1-877-737-2840.

~ REMOTE CONTROLLER: 9007603005 (OPTIONAL) ~

PROBLEM	POSSIBLE SOLUTIONS
Remote controller does not display anything when the power button is turned on.	<p>Press the ON/OFF button.</p> <p>If the lamp lights up ⇒</p> <ul style="list-style-type: none"> • This is normal. When the unit has not operated for five minutes or more, the display turns off to conserve energy. <p>If the lamp does not light ⇒</p> <ul style="list-style-type: none"> • Make sure the unit has power supply. • Make sure the connection to the unit is correct.(p. 20)
An ERROR code is displayed.	<ul style="list-style-type: none"> • Please see the p. 38.

~ EASY-LINK SYSTEM ~

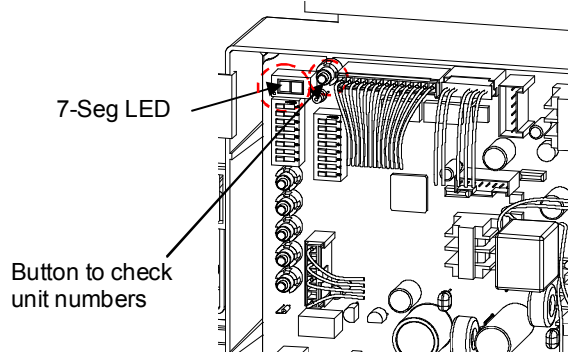
PROBLEM	POSSIBLE SOLUTIONS
How are the unit numbers assigned?	<ul style="list-style-type: none"> • For an Easy-Link system, other than the PARENT Unit (which is always labeled #1), all the other units (the CHILD units) are numbered randomly. • To check which numbers are assigned to which units, push the button on the computer board of a unit as shown below. The unit number will be displayed on the 7-Seg LED. <div style="text-align: right;">  <p>The diagram shows a close-up of the computer board. A red circle highlights a small button labeled 'Button to check unit numbers'. To its left is a 7-segment LED display labeled '7-Seg LED'. The board is populated with various electronic components like resistors and integrated circuits.</p> </div>

TROUBLESHOOTING – ERROR CODES

- The 710 units are self diagnostic for safety and convenience when trouble shooting.
- If there is a problem with the installation or the unit, it will display a numerical error code on the remote controller (if installed) or on the 7-Seg LED of the central computer board and section computer board to communicate the source of the problem.
- Consult the following chart for the cause of each error code.

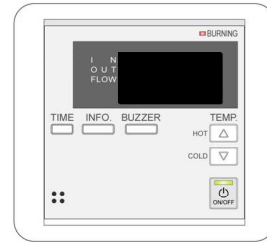
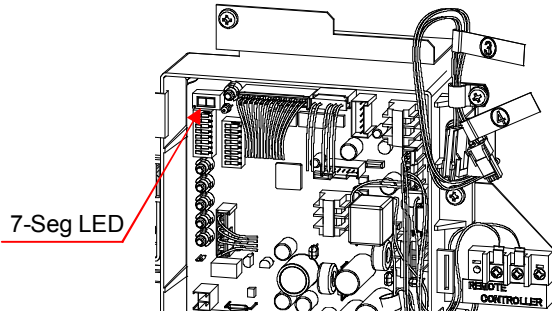

Remote controller (Optional)

Error Code	Malfunction description	Error Code	Malfunction description	Error Code	Malfunction description
031	Dipswitch Setting fault	391	Air-fuel Ratio Rod Failure	661	Water Control Valve Fault (Bypass function)
101	Warning for 991 Error Code	441	Flow Sensor Failure	701	Computer board Fault
111	Ignition Failure	510	Abnormal Main Gas Valve	721	False Flame Detection
121	Flame blows out	551	Abnormal Gas Solenoid Valve	741	Miscommunication between water heater and remote controller
311	Output Thermistor Failure	611	Fan Motor Fault	761	Miscommunication in Easy-link OR Multi-unit system
321	Inlet Thermistor Failure	631	Abnormal External Pump	991	Abnormal burning
331	Mixing Thermistor Failure	651	Water Control Valve Fault (Flow Adjustment function)		

Single Unit

- The 7-Seg LED displays the 3-digit error codes one digit at a time. The remote controller (if installed) displays the whole 3-digit error code at once.

Example:

- If your unit has the “321” error code (inlet thermistor),
- The 7-Seg LED, will flash the 3-digit error code one digit at a time. The 7-Seg LED will display “3”... “2”... “1”, and then repeat the 3 digits.
 - The remote controller, however, will display “321” on its screen, in its entirety.

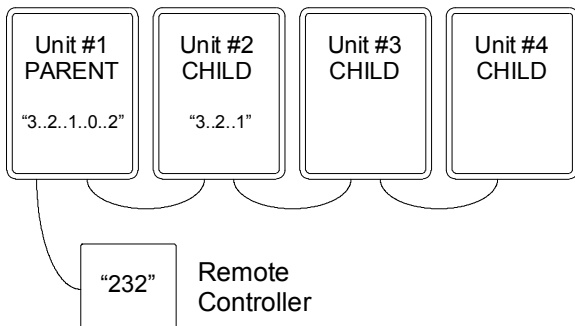

Easy-Link

- The 7-Seg LED on the PARENT unit displays a 5-digit number to signify which unit in the Easy-Link system has the error, and what the error code is. The 7-Seg LED displays the number one digit at a time.
- The remote controller (if installed) displays a 3-digit number which also signifies which unit has the error, and what the error code is.
- The unit that has the error in an Easy-Link system will display the error code on its 7-Seg LED in exactly the same way as if it were only a Single Unit.

Example:

- If Unit #2 has the “321” error code (inlet thermistor),
- The 7-Seg LED on the PARENT unit will display “3”... “2”... “1”... “0”... “2”, displaying only one digit at a time. The first 3 numbers indicate the error code. The last two numbers indicate that Unit #2 has the error.
 - The remote controller, however, will display “232” on its screen in its entirety. The first “2” indicates that Unit #2 has the error. The “32” indicates the first two digits of the “321” error code.
 - The 7-Seg LED on Unit #2 will display “3”... “2”... “1”, just like in the Single Unit example.

WIRING DIAGRAM

A wiring diagram is located on the inside front panel of the appliance.

Electrical Rating: 120 VAC, 60 Hz.

Note: If any of the original wiring supplied with this appliance must be replaced, it must be replaced with appliance wiring material (180c) or its equivalent. Wires are available through the manufacturer.

BK: BLACK	LB: LIGHT BLUE	G: GREEN	O: ORANGE
P: PURPLE	BL: BLUE	Y: YELLOW	BR: BROWN
W: WHITE	R: RED	GY: GRAY	

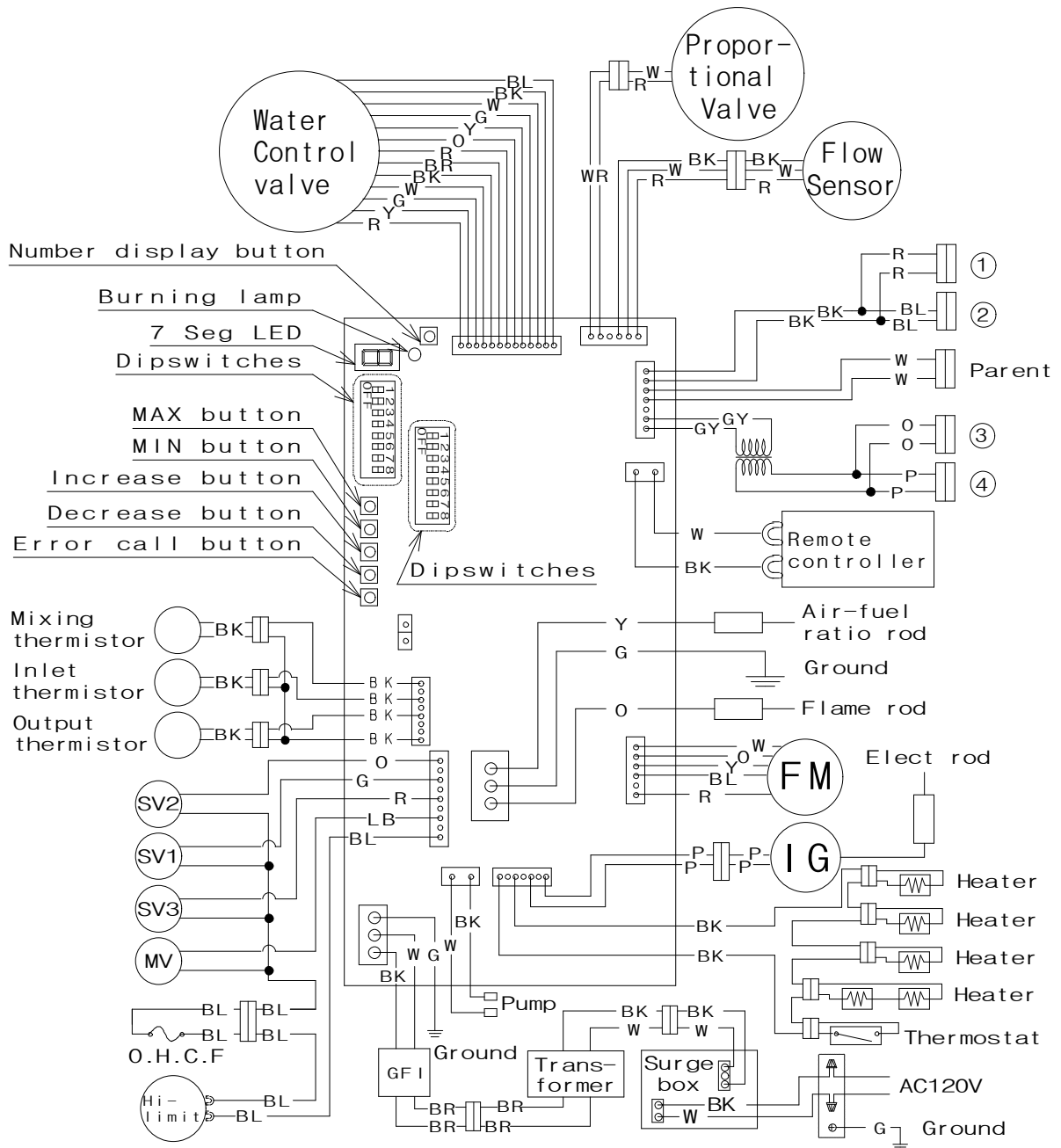

OPERATING SAFETY

FOR YOUR SAFETY READ BEFORE OPERATING

WARNING: If you do not follow these instructions exactly, a fire or explosion may result causing property damage, personal injury or loss of life.

- A. This water heater does not have a pilot. It is equipped with an ignition device that automatically lights the burner. Do not try to light the burner by hand.
- B. BEFORE OPERATING smell all around the water heater area for evidence of leaking gas. Be sure to smell next to the floor because some gas is heavier than air and will settle on the floor.

WHAT TO DO IF YOU SMELL GAS.

- Do not try to light any appliance.
 - Do not touch any electric switch, do not use any phone in your building.
 - Immediately call your gas supplier from a neighbor's phone. Follow the gas supplier's instructions.
 - If you cannot reach your gas supplier, call the fire department.
- C. Use only your hand to turn the gas valve knob. Never use tools. If the knob will not turn by hand, don't try to repair it. Call a qualified service technician. Forced or attempted repair may result in a fire or explosion.
 - D. Do not use this water heater if any part has been under water. Immediately call a qualified service technician to inspect the water heater and to replace any damaged parts.

OPERATING INSTRUCTIONS

1. **STOP!** Read the safety information above or in the Owners Manual.
2. Turn off all electric power to the water heater.
3. Do not attempt to light the burner by hand.
4. Turn the manual gas valve located on the outside of the unit clockwise \cup to the off position.
5. Wait five (5) minutes to clear out any gas. If you then smell gas. STOP! Follow "B" in the safety information above on this label. If you don't smell gas, go to next step.
6. Turn the manual gas valve located on the outside of the unit counter clockwise \cup to the ON position.
7. Turn on all electrical power to the water heater.
8. If the water heater will not operate, follow the instructions "to Turn Off Gas to water heater" and Call your service technician or gas supplier.

TO TURN OFF GAS TO APPLIANCE

1. Turn off all electric power to the water heater if service is to be performed.
2. Turn the manual gas valve located on the outside of the unit clockwise \cup to the off position.

DANGER

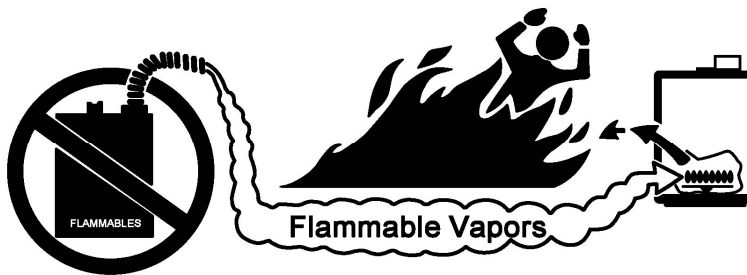

Vapors from flammable liquids will explode and catch fire causing death or severe burns.

Do not use or store flammable products such as gasoline, solvents or adhesives in the same room or area near the water heater.

Keep flammable products:

1. Far away from heater
2. In approved containers
3. Tightly closed
4. Out of children's reach

Vapors:

1. Cannot be seen
2. Vapors are heavier than air
3. Go a long way on the floor
4. Can be carried from other rooms to the main burner by air currents

WARNING: Do not install water heater where flammable products will be stored.

Read and follow water heater warnings and instructions. If owner's manual is missing, contact the retailer or manufacturer.

WARNING

The outlet hot water temperature of the water heater is factory set at 120 °F (49°C). Use this heater at your own risk. The set outlet water temperature can cause severe burns instantly or death from scalds. Test the water before bathing or showering. Do not leave children or an infirm person in the bath unsupervised.

DANGER



Hot Water Heater temperature over 125 °F (52°C) can cause severe burns instantly or death from scalding. Children, disabled and elderly are at the highest risk of being scalded. Feel water temperature before bathing or showering. Temperature limiting valves are available. Ask a professional person.

WARNING: California Proposition 65 lists chemical substances known to the state to cause cancer, birth defects, death, serious illness or other reproductive harm. This product may contain such substances, be their origin from fuel combustion (gas, oil) or components of the product itself.

APPLICATIONS

Space Heating Applications

- Toxic chemicals used in boiler treatments such as alcohol, glycerol and glycol group must not be introduced into the system when used for open loop potable water and space heating.
- The 710 can be used to supply potable water and space heating and shall not be connected to any heating system or component(s) previously used with non-potable water where any chemicals were added to the water heating appliances.
- When the system requires water for space heating at temperatures higher than required for other uses, a means such as a mixing valve shall be installed to temper the water for those other uses in order to reduce scald hazard potential.
- Water temperature over 125 °F can cause severe burns instantly or death from scalds.
- Chemicals such as diluted Glycol can be used for radiant floor, Hydro/fan coil air or Baseboard heating only. The diluted solution of glycol must contain between 25% and 55% of Glycol. Be aware that in closed-loop glycol systems, low pressure in the heat exchanger can cause low-temperature boiling, resulting in excessive noise and damage to the water heater. Consult with the glycol maker for specifications prior to use.

Re-circulation:

* The recirculation pump is to be controlled by:

-Dual-set aquastat (recommended w/timer)

OR

-710 Pump Control set to "Recirculation Mode"

* The recirculation pump is to provide no less than 2 GPM and no more than 4 GPM through each activated unit in the system.

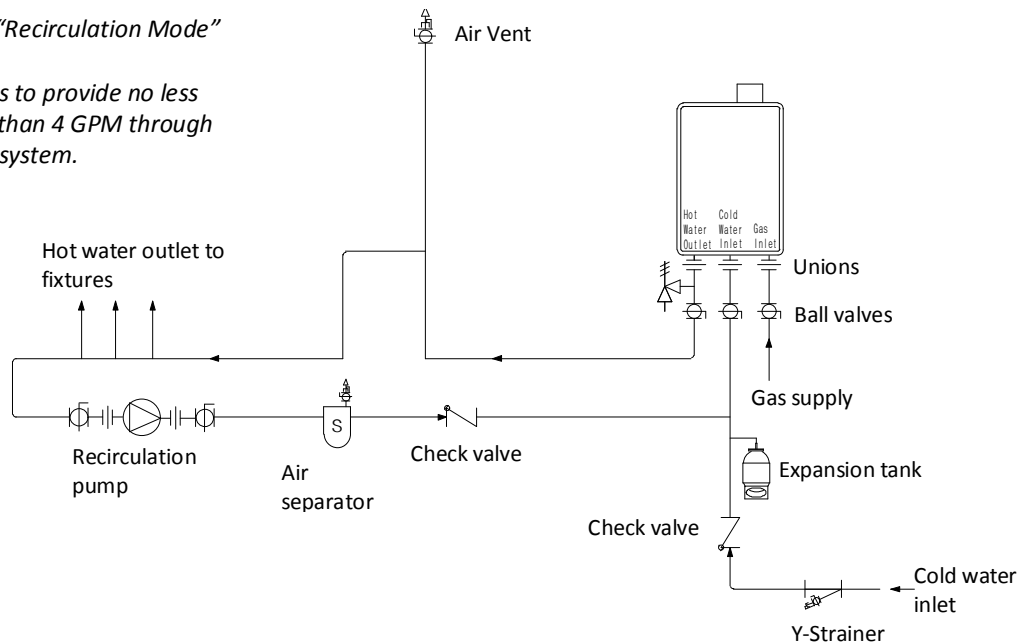

This is a concept drawing only.

Dual-purpose hot water heating (Domestic and Space Heating):

Diagrammatic Layout of Radiant Heating and Domestic Water Heater Per Mass. Code

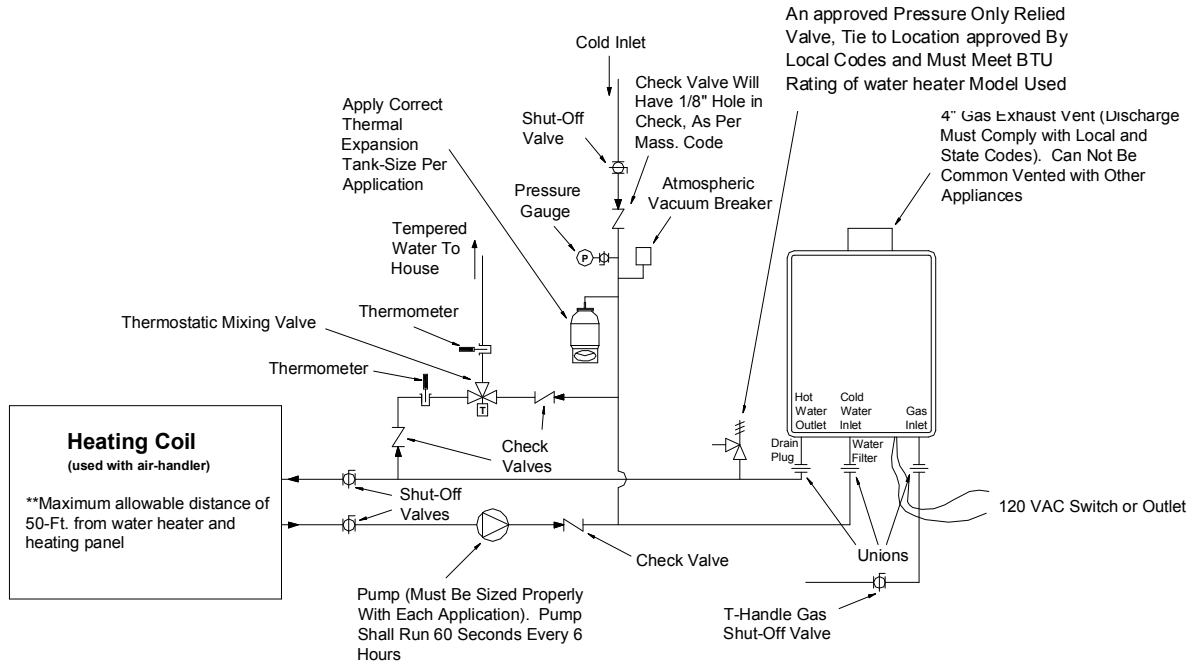

* The circulation pump is to provide no less than 2 GPM and no more than 4 GPM through each activated unit in the system.

Priority Control Devices such as a flow switch, an Aquastat or other electronic controller can be used to prioritize the domestic water system over the heating system.

Warning: Follow all local codes, or in the absence of local codes, follow the most recent edition of the National Standard Code, ANSI Z21.10.3.

Warning: This illustration is a concept design only. The reference to the 1/8th hole in check is only for the State of Massachusetts. There are a wide variety of variations to the application of controls and equipment presented. Designers must add all necessary safety and auxiliary equipment to conform to code requirements and design practice. For more details, contact the manufacturer.

ADDITIONAL CLEARANCES

Please follow all local and national codes in regards to proper termination clearances. In the absence of such codes, the following clearances can be used as guidelines. Local codes supersede these guidelines.

For sidewall terminations

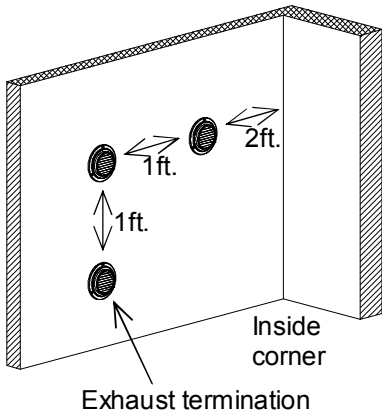

For multiple sidewall exhaust terminations (e.g. multi-unit systems), an exhaust termination must be at least 1 ft. away from another exhaust termination. An exhaust termination must also be at least 2 ft. away from an inside corner (if the adjacent wall is less than 2 ft. of length, the minimum required distance away from the inside corner will be equal to the length of the wall).

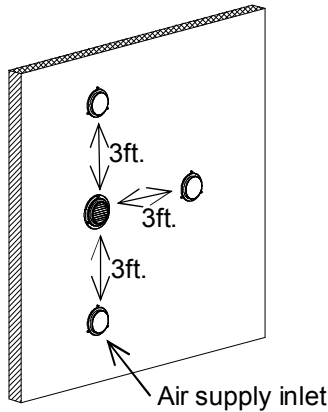

For direct-vent sidewall terminations that use two separate penetrations for the intake and exhaust, distance the intake and exhaust terminations at least 3 ft. away from each other, no matter the orientation.

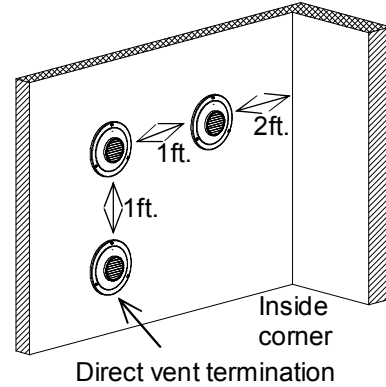

For multiple-unit, direct-vent sidewall terminations that combine the intake and exhaust into a single penetration, space each direct-vent termination at least 1 ft. away from each other, no matter the orientation. A direct-vent termination must also be at least 2 ft. away from an inside corner (if the adjacent wall is less than 2 ft. of length, the minimum required distance away from the inside corner will be equal to the length of the wall).

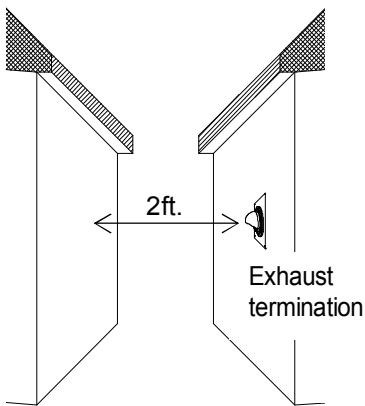

Exhaust and/or direct-vent sidewall terminations should be at least 2 ft. away from an opposite surface/wall. Do not place the termination directly in front of an opening into a building.

For rooftop terminations

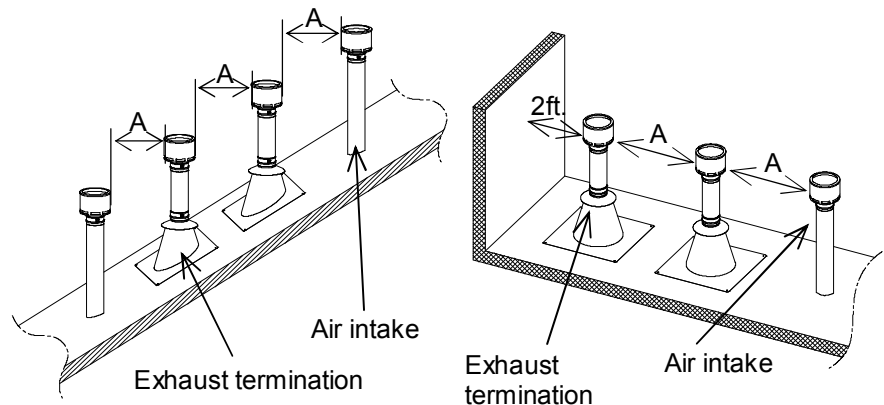

A: in accordance with local codes

For multiple-unit rooftop terminations (whether for standard indoor or direct-vent installations) space all exhaust and intake terminations in accordance with local codes. An exhaust termination must be spaced from a wall or surface in accordance with local codes as well. In the absence of such a code, an exhaust termination must be a horizontal distance of at least 2 ft. away from a wall or surface.

OPTIONAL ITEMS

1. Temperature Remote Controller: 9007603005



The Temperature Remote Controller has two functions. It allows the output temperature from the water heater to be adjusted within the range of 100 °F to 185 °F, and it also works as a diagnostic tool that will give a concise error code whenever there is a problem with the unit. The temperature options are 100°F, 105°F, 110°F, 115°F, 120°F, 125°F, 130°F, 135°F, 140°F, 145°F, 150°F, 155°F, 160°F, 165°F, 170°F, 175°F, 180°F and 185°F. See the trouble shooting section for information on possible error codes.

2. Multi system controller: 9007675005



The multi- system controller can control a maximum of 20 water heaters, from 24,000 BTU to 4,800,000 BTU. It also works as a diagnostic tool that will give a concise error code whenever there is a problem with the unit. Usage of the 9007675005 requires having the 9007603005 remote controller.

3. Backflow preventer: 9007678005



The Backflow preventer prevents the backflow of air through the exhaust vent. This helps prevent harmful exhaust gases from entering the home, as well as helping to prevent the unit from freezing in areas where cold air can be blown or drawn into the exhaust system. Install this vent damper in accordance with the manufacturer's installation instructions, and any applicable codes.

4. Vent Cap: 9007676005



The Vent Cap is for outdoor installation with the 710 water heater. The cap is installed on the top of the unit, instead of connecting an exhaust vent pipe. The cap will prevent any debris that might be in the environment from entering the unit and causing damage or a fire hazard, as well as preventing rain or other weather from entering the unit.

5. Direct-Vent Kit: 9007668005



This kit can be used convert the 710 from a conventional vent system to a direct-vent (or sealed combustion) system. This is a CSA tested conversion kit. Install this conversion kit in accordance with the manufacturer's installation instructions and any applicable codes.

6. Pipe cover: 9007672005



The Pipe cover protects the plumbing pipes to the 710 from unexpected adjustments. This pipe cover is fixed to the bottom of the water heater, which hides the plumbing and improves the visual aspects of the whole installation for the water heater.

7. Wall thimble with Termination: 9007608005 and 9007609005



Louver Termination
9007608005



Hood Termination
9007609005

These terminations are used when venting out through the wall and are compatible with the T-Vent pipe system. These terminations are special stainless steel vents for gas appliances and are UL listed as Category II, III and IV. There are two types of terminations: the Louver termination and the Hood termination. For different wall thicknesses, there are two ranges of lengths available (refer to the venting brochure for details). Install these vent terminations in accordance with the manufacturer's installation instructions and any applicable local codes.

COMPONENTS DIAGRAM

Case assembly

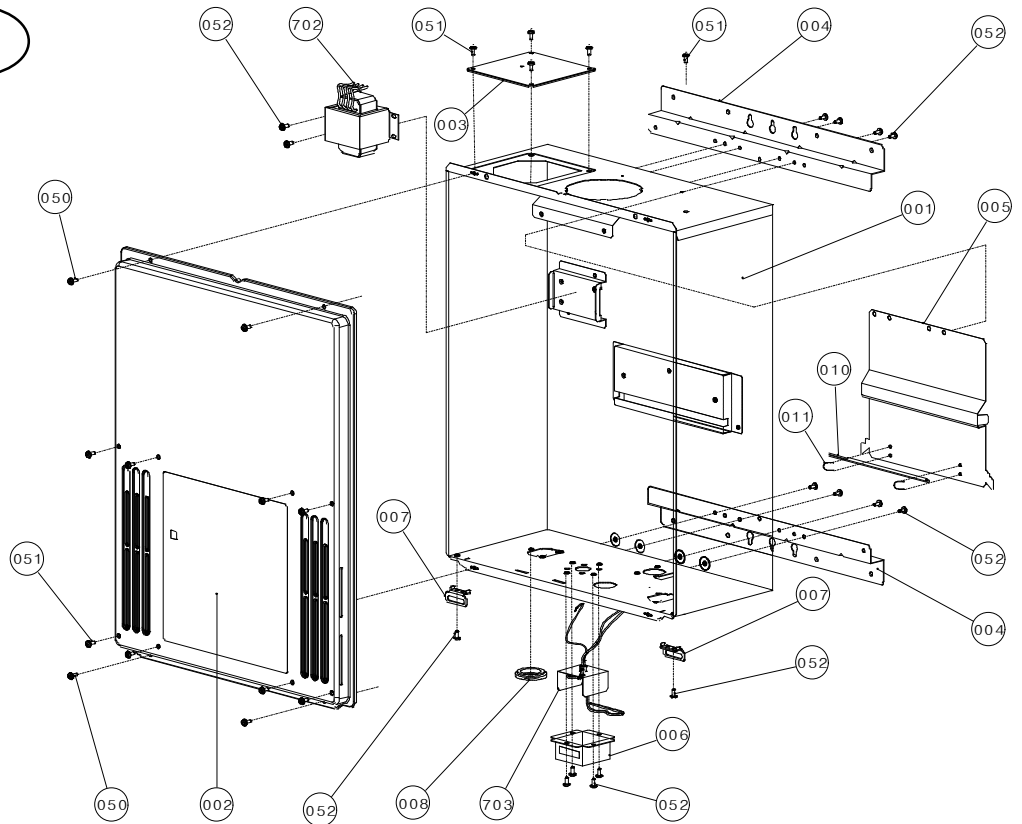

Computer board assembly

Other than Part# 706, the 710 and the 710 ASME models share the same components.

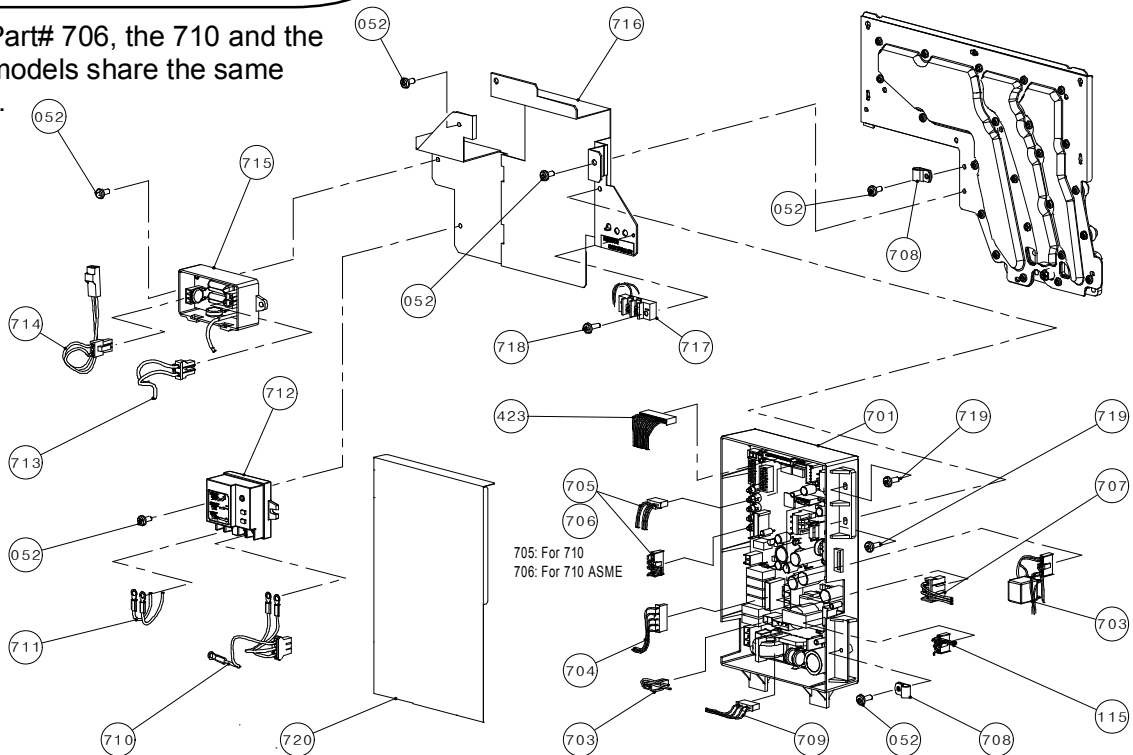

Burner assembly

The 710 and the 710 ASME models share the same components.

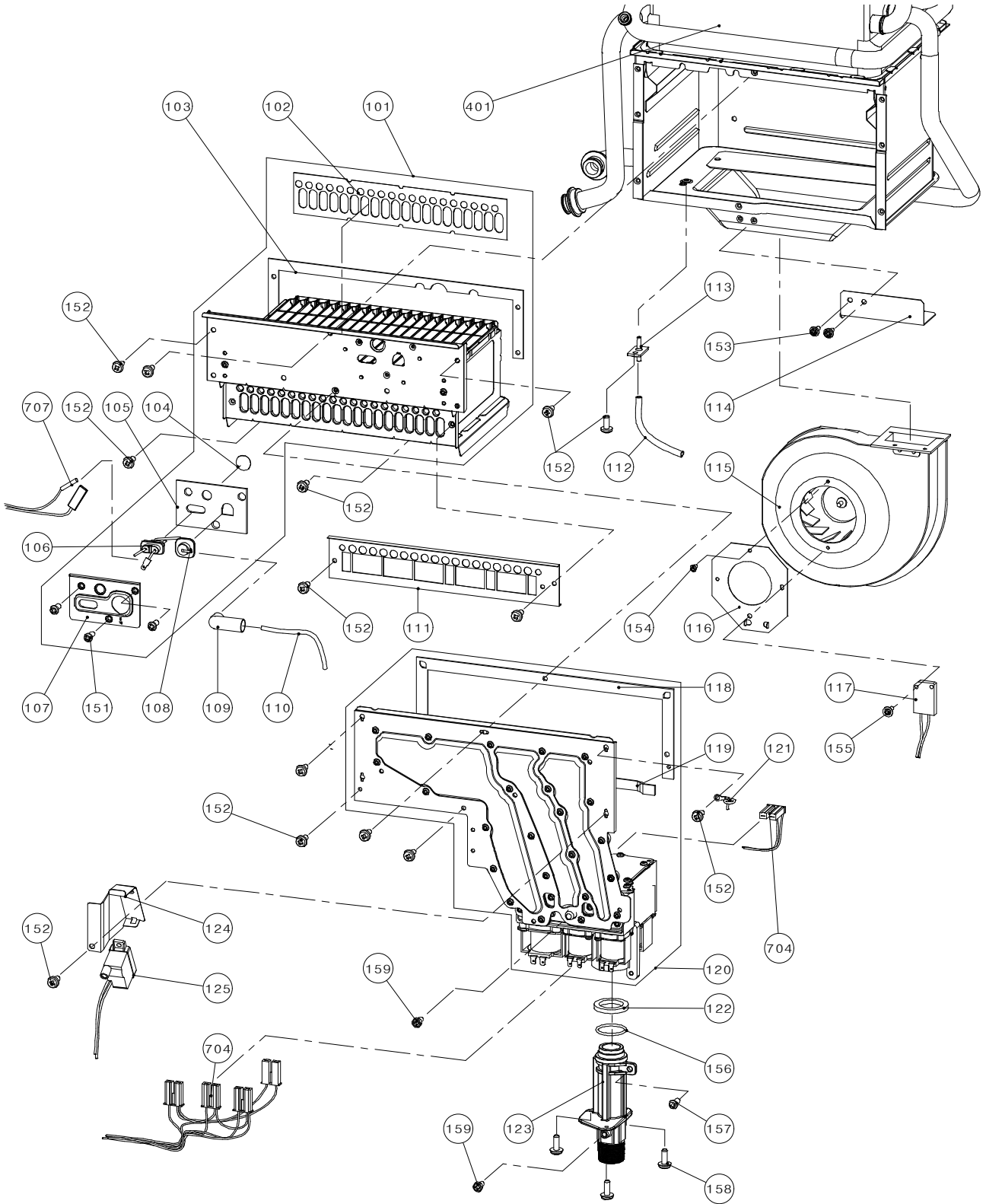

Water way assembly

Other than Part# 211, Part# 439, Part# 440 and Part# 441, the 710 and the 710 ASME models share the same components.

710

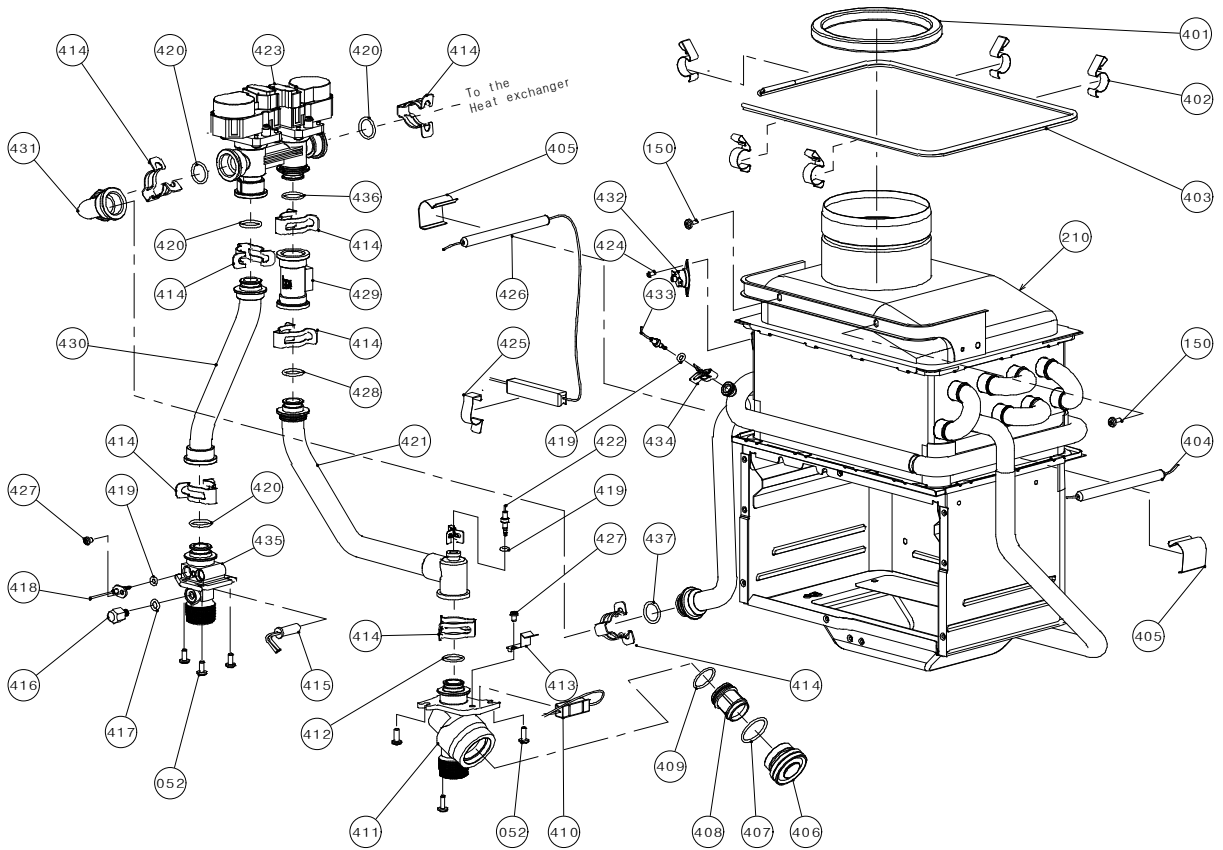

710 ASME

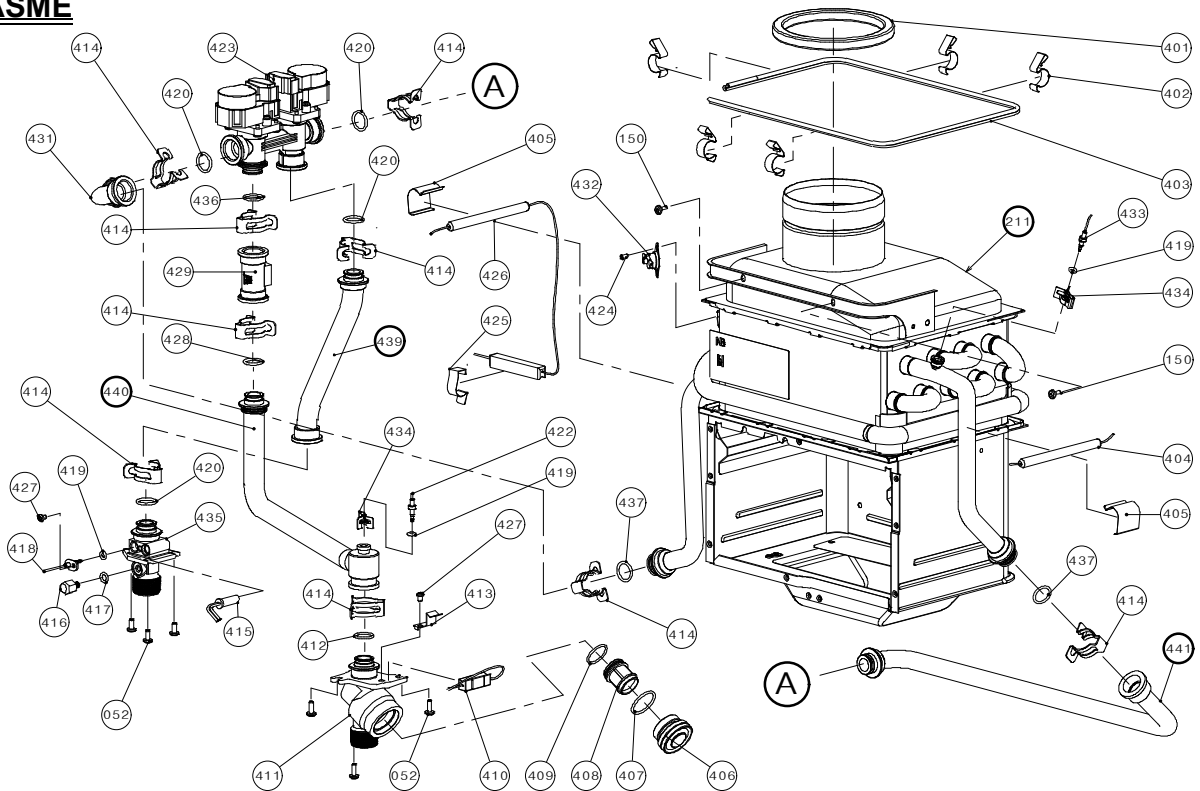

PARTS LIST

Other than the burner assembly (No.211), hot pipe (No.439), cold pipe (No.440), connection pipe (No.441) and "flow sensor, gas proportional valve connection and thermistors" wire (No.706), all of the 710 ASME's components are the same as the 710.

Item#	Part#	Description	Item#	Part#	Description
001	319143-287	Case assembly	120	319143-305	Manifold assembly with gas valve assembly LP
002	319143-303	Front cover			
003	319143-285	Air blockage plate		319143-306	Manifold assembly with gas valve assembly NA
004	319143-225	Bracket			
005	319143-283	Back guard panel	121	319143-048	Wire cramp
006	319143-014	Junction box	122	319143-342	Gas inlet ring
007	319143-335	Fixing plate	123	319143-307	Gas inlet
008	319143-334	Rubber bush	124	319143-051	Igniter plate
			125	319143-052	Igniter
010	319143-016	Overheat-cut-off-fuse for combustion chamber	151	319143-059	Pan screw M4×8
011	319143-017	Fastener	152	319143-060	Screw M4×10
051	319143-325	Screw M4×10 (W/Washer)	153	319143-061	Pan screw M4×12 (W/Washer)
052	319143-026	Screw M4×10 (Coated)	154	319143-330	Screw M3×6
101	319143-299	Burner assembly	155	319143-327	Screw M3×10
102	319143-300	Burner gasket	156	319143-351	O-ring P26 NBR (Black)
103	319143-301	Guide plate gasket	157	319143-062	Pan screw M4×10
104	319143-033	Burner window	158	319143-325	Screw M4×10 (W/Washer)
105	319143-034	Rod holder gasket	159	319143-063	Hex head screw M4×8
106	319143-035	Flame rod	160	319143-090	Pan screw M4×6 (W/Washer)
107	319143-036	Rod holder	210	319143-302	Heat exchanger assembly for 710
108	319143-037	Igniter rod			
109	319143-038	Rod cap	211	319143-314	Heat exchanger assembly for 710 ASME
110	319143-345	High voltage igniter cable			
111	319143-298	Damper	401	319143-065	Silicon ring
112	319143-346	Urethane tube	402	319143-066	Fuse fixing plate 18
113	319143-042	Pressure port	403	319143-286	Overheat-cut-off-fuse
114	319143-281	Fan motor fixing plate	404	319143-224	Pipe heater 122
115	319143-043	Fan motor	405	319143-088	Heater fixing plate
116	319143-282	Fan damper	406	319143-070	Filter plug
117	319143-185	Freeze protection thermostat	407	319143-071	O-ring P25 FKM
118	319143-304	Manifold gasket A	408	319143-072	Water inlet filter
119	319143-336	Manifold gasket B	409	319143-073	O-ring JASO# 1021 FKM

Item#	Part#	Description	Item#	Part#	Description
410	319143-068	Heater 101	437	319143-349	O-ring P18 FKM
411	319143-074	Water inlet	439	319143-316	Hot pipe for 710 ASME
412	319143-075	O-ring JASO# 1016 FKM	440	319143-315	Cold pipe for 710 ASME
413	319143-076	Heater plate	441	319143-317	Connection pipe for 710 ASME
414	319143-077	Fastener "16AG"	701	319143-279	710 PCB
415	319143-078	Heater	702	319143-309	Transformer
416	319143-079	Outlet drain plug	703	319143-322	Junction box inner plate
417	319143-080	O-ring P6 FKM	704	319143-290	Gas valve wire
418	319143-081	Mixing thermistor	705	319143-293	"Flow sensor, Gas proportional valve connection and Thermistors" wire for 710
419	319143-082	O-ring P4 FKM	706	319143-324	"Flow sensor, Gas proportional valve connection and Thermistors" wire for 710 ASME
420	319143-083	O-ring P16 FKM	707	319143-292	Flame rod wire
421	319143-288	Cold pipe for 710	708	319143-143	Nylon clamp
422	319143-085	Inlet thermistor	709	319143-320	Igniter & Freeze protection wire
423	319143-086	Water control valve	710	319143-291	AC100V wire
424	319143-087	Screw M3×6	711	319143-297	AC100V Transformer connecting wire
425	319143-125	Heater fixing plate 16	712	319143-227	Ground fault circuit interrupter
426	319143-321	Pipe heater 212	713	319143-296	Power supply code assembly
427	319143-090	Pan screw M4×6 (W/Washer)	714	319143-295	AC120V Transformer connecting wire
428	319143-091	O-ring P15 FKM	715	319143-284	Surge box
429	319143-092	Flow sensor	716	319143-280	PCB fixing plate
430	319143-289	Hot pipe for 710	717	319143-294	Remote controller terminal
431	319143-318	L joint	718	319143-331	Screw M3×12
432	319143-095	Hi-limit switch	719	319143-343	Screw M4×12
433	319143-096	Output thermistor	720	319143-323	PCB cover
434	319143-097	Fastener "4-11"			
435	319143-098	Water outlet			
436	319143-099	O-ring JASO# 1017 FKM			

OUTPUT TEMPERATURE CHART

Out Put Temperature vs. GPM (Max. 9.0 GPM) with Various Ground Water Temperature
Correct Gas pipe size can be expect this chart

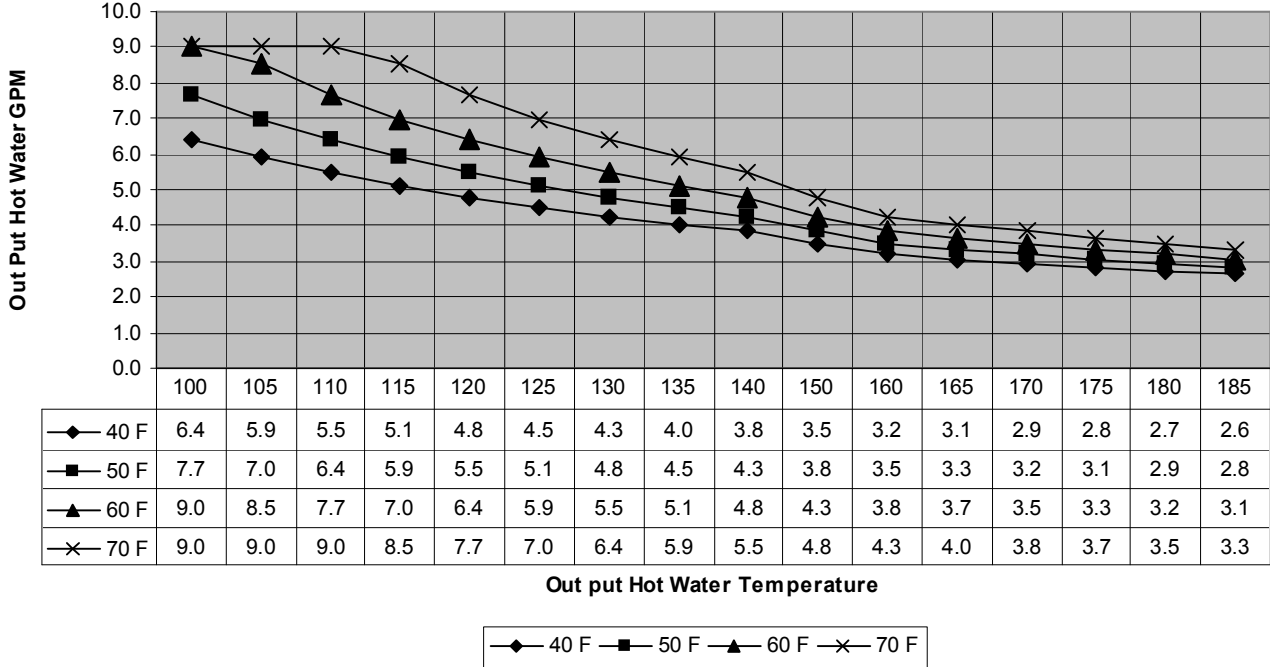

*When the set temperature is 150°F or higher, maximum flow rate is limited to 5.3 GPM.

LIMITED WARRANTY

- General terms of limited warranty:
This limited warranty gives you specific legal rights, and you may also have other rights which vary from State to State. The manufacturer will honor the warranty to the original retail buyer at the original location only, and it is not transferable. **THIS WARRANTY COVERS ONLY FAILED MECHANICAL AND ELECTRICAL PARTS DUE TO FACTORY DEFECTS UNDER NORMAL USAGE FOR THE PRODUCT'S INTENDED PURPOSES AND WITHIN THE APPLICABLE PERIOD SPECIFIED IN THE FOLLOWING TABLES. ONLY DIRECT DAMAGES SHALL BE RECOVERABLE BY A CLAIMANT UNDER THIS LIMITED WARRANTY AND, IN NO EVENT, WHETHER AS A RESULT OF BREACH OF CONTRACT, BREACH OF WARRANTY, TORT LIABILITY (INCLUDING NEGLIGENCE), STRICT LIABILITY, INDEMNITY OR OTHERWISE THE MANUFACTURER WILL BE LIABLE FOR ANY SPECIAL, INCIDENTAL, OR INDIRECT CONSEQUENTIAL DAMAGES INCLUDING PROPERTY DAMAGE, PERSONAL DAMAGES, LOSS OF USE, OR INCONVENIENCE. SOME STATES DO NOT ALLOW THE EXCLUSION OR LIMITATION OF INCIDENTAL OR CONSEQUENTIAL DAMAGES, SO THE ABOVE LIMITATION MAY NOT APPLY TO YOU.**

2. Warranty for models: 710, 710 ASME

Application		HX ⁽¹⁾	Parts	Labor	
Single Family Domestic Hot Water	No Recirculation	12	5	1 ⁽³⁾	
	On-Demand Recirculation ⁽²⁾				
	w/ Standard Recirculation	Aquastat Control	5		3
		Pump Control			
		Timer Only			
No Pump Control (24 hr.)	3	3			
Commercial or Multi-Family Domestic Hot Water	No Recirculation	5	5	1 ⁽³⁾	
	On-Demand Recirculation ⁽²⁾				
	w/ Standard Recirculation	Aquastat Control	5		3
		Pump Control			
		Timer Only			
No Pump Control (24 hr.)	3	3			
Heating ⁽⁴⁾	All Types	5	5	1 ⁽³⁾	

[Unit: Year]

(1) Heat exchanger

(2) An on-demand recirculation system is a system that utilizes either a push-button or other type of manual activation (as opposed to automatic activation with a temperature sensor or timer) to activate the circulation pump. An on-demand recirculation system can use either the existing cold water line as the return line or have its own dedicated return line.

(3) Limited Labor Coverage

- The manufacturer will provide for reasonable labor charges associated with warranty repairs or replacements within one (1) year from the date of purchase. The manufacturer will only pay directly to the service provider.
- Warranty service must be performed by an authorized Service Representative. A list of authorized Service Representatives is available upon request.
- All warranty claims and warranty service must be authorized and approved by the manufacturer.

(4) Includes dual-purpose applications (combination heating and domestic).

3. Repair, Replacement or Refund:

The manufacturer or its authorized Service Representative will, at its sole discretion, repair or replace any failed or defective mechanical or electrical parts, or components thereof, or, if the manufacturer or its authorized Service Representative cannot replace said parts, and repair is not commercially practicable, the manufacturer or its authorized Service Representative will refund the purchase price. The manufacturer or its authorized Service Representative may, at its sole discretion, use new, refurbished or reconditioned parts.

4. Limitation on Duration of Implied Warranties:

ANY IMPLIED WARRANTIES ARISING UNDER STATE LAW, INCLUDING THE IMPLIED WARRANTIES OF FITNESS FOR A PARTICULAR PURPOSE AND MERCHANTABILITY, SHALL IN NO EVENT EXTEND PAST THE EXPIRATION OF ANY WARRANTY PERIOD HEREUNDER. SOME STATES DO NOT ALLOW LIMITATIONS ON HOW LONG AN IMPLIED WARRANTY LASTS, SO THE ABOVE LIMITATION MAY NOT APPLY TO YOU.

5. THIS WARRANTY WILL NOT COVER THE FOLLOWING:

- Any product that is not installed by a licensed plumber, gas installer, or contractor.
- Damages due to accidents, abuse, misuse, improper installation, misapplication, or incorrect sizing.
- Damages due to fires, flooding, freezing, electrical surges, or any Acts of God.
- Damages due to unauthorized alterations, attachments, and/or repairs.
- Damages due to a lack of maintenance (e.g. water filter, water treatment system, vent blockage, etc.)
- Any product installed in an improper environment (e.g. corrosive, dusty, chemically contaminated, excessive lint, etc.)
- Freeze damage that occurs without taking proper preventive measures as described in the installation manual
- Condensate damage due to improperly installed or lack of a condensate trap (drain).
- Any product not installed in compliance with all applicable local & state codes, ordinances, and good trade practices.
- Any product sold to or installed in areas outside of the fifty states (and the District of Columbia) of the United States of America and Canada.
- Any product installed in applications that cause the water heater to activate more than 300 times per day (this averages to an activation every 5 minutes in a 24-hour period).
- Any failures that are not due to defects in materials or workmanship (mechanical and/or electrical parts).
- Damages due to improper installation:
 - Gas: incorrect gas pipe sizing, incorrect gas meter sizing, incorrect gas type, and/or gas pressures that fall outside the product's specified range.
 - Water: incorrect water pipe sizing, water pressures that fall outside the product's specified range, recirculation flow rates that fall outside the product's specified range (air removal), and/or lack of proper methods of air removal in a closed-loop, circulation system (see installation manual for details).
 - Electric: supply power voltages that fall outside the product's specified range.
- Damages due to water quality:
 - Introduction of liquids other than potable water or potable water / glycol mixtures into the product.
 - Introduction of pool water, spa water, or any chemically treated water into the product
 - Introduction of hard water measuring more than 7 grains per gallon (120 ppm) for single family domestic applications or more than 4 grains per gallon (70 ppm) for all other types of applications into the product
 - Introduction of untreated or poorly treated well water into the product
 - Introduction of water with pH levels less than 6.5 and greater than 8.5 into the product.

ATM32
63T051